

TM 9-2920-258-30&P

TECHNICAL MANUAL

**DIRECT SUPPORT
MAINTENANCE MANUAL
(INCLUDING REPAIR PARTS
AND SPECIAL TOOLS)**

**ALTERNATOR,
180 AMPERES,
MODEL 5520AB**

**NSN 2920-01-288-0497
(P/N 12268305)**

Approved for public release; distribution is unlimited.

HEADQUARTERS, DEPARTMENT OF THE ARMY

25 APRIL 1989

WARNING

This list summarizes critical **warnings** in this manual. They are repeated here to let you know how important they are. Study these **warnings** carefully; they can save your life and the lives of personnel with whom you work.

WARNING

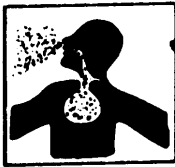

Dry cleaning solvent P-D-680 is **toxic** and **flammable**. Wear protective goggles, gloves and apron, and use only in a well ventilated area. Avoid contact with skin, eyes and clothes, and don't breathe vapors. **Do not** use near open flame or excessive heat. The flash point is 100-138°F (38-59°C). If you become dizzy while using cleaning solvent, get fresh air immediately and get medical aid. If contact with eyes is made, wash your eyes with water and get medical aid immediately.

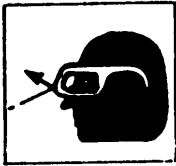

WARNING

Air pressure in excess of 10 psi (69 kPa) can injure personnel. **Do not** direct pressurized air at yourself or others. Always wear goggles.

WARNING



Energized systems and equipment can burn you. If **MASTER SWITCH** is **ON**, electrical system and equipment will be energized. Make sure **MASTER SWITCH** is **OFF** when you work on electrical systems or equipment.

TECHNICAL MANUAL

**DIRECT SUPPORT
MAINTENANCE MANUAL
(INCLUDING REPAIR PARTS
AND SPECIAL TOOLS)**

**ALTERNATOR,
180 AMPERES,
MODEL 5520AB**

NSN 2920-01-288-0497
(P/N 12268305)

REPORTING OF ERRORS AND RECOMMENDING IMPROVEMENTS

You can help improve this manual. If you find any mistakes or if you know of a way to improve the procedure, please let us know. Mail your letter, DA Form 2028 (Recommended Changes to Publications and Blank Forms), or DA Form 2028-2 located in the back of this manual direct to: Commander, US Army Tank-Automotive Command, ATTN: AMSTA-MB, Warren, Michigan 48397-5000. A reply will be furnished to you.

Approved for public release; distribution is unlimited.

TABLE OF CONTENT

	PARAGRAPH	PAGE
CHAPTER 1- INTRODUCTION		
SECTION I General Information		
Scope	1-1	1-1
Maintenance Forms, Records and Reports	1-2	1-1
Destruction of Army Materiel To Prevent Enemy Use	1-3	1-1
Preparation for Storage or Shipment	1-4	1-1
Reporting Equipment Improvement Recommendations (EIR)	1-5	1-1
SECTION II Equipment Description and Data		
Equipment Characteristics and Features	1-6	1-1
Location and Description of Major Components	1-7	1-2
Equipment Data	1-8	1-3
Safety Care and Handling	1-9	1-3

CHAPTER 2- ALTERNATOR TROUBLESHOOTING		
SECTION I Repair Parts, Special Tools, TMDE and Support Equipment		
Common Tools and Equipment	2-1	2-1
Special Tools	2-2	2-1
Repair Parts	2-3	2-1
SECTION II Troubleshooting		
Purpose	2-4	2-1
Troubleshooting Procedures	2-5	2-1
 CHAPTER 3- ALTERNATOR REPAIR		
Principles of Operation	3-1	3-1
General Instructions	3-2	3-1
Replacement of Parts	3-3	3-2
Ball and Roller Bearings	3-4	3-2
Removing Burrs, Scratches and Raised Metal	3-5	3-2
Repairing Damaged Threads	3-6	3-3
Alternator Cleaning Instructions	3-7	3-3
Alternator Repair	3-8	3-4
 APPENDIX A - REFERENCES		
A-1 General		A-1
A-2 Forms		A-1
A-3 Technical Manuals		A-1
A-4 Technical Bulletins		A-2
 APPENDIX B - DIRECT SUPPORT MAINTENANCE REPAIR PARTS AND SPECIAL TOOLS LIST		
		B-1
 APPENDIX C - EXPENDABLE/DURABLE SUPPLIES AND MATERIALS LIST		
		c-1
 APPENDIX D - ALTERNATOR TEST STAND PROCEDURES		
SECTION I Sun Electric Corporation Model AGT-9 or AGT-9A Test Stand		
D-1 General		D-1
D-2 Testing Procedure Without Regulator		D-1
D-3 Testing Procedure With Regulator		D-3
SECTION II United 500-Ampere Model GASR-500 Test Stand		
D-1 General		D-8
D-2 Testing Procedure Without Regulator		D-8
D-3 Testing Procedure With Regulator		D-12

CHAPTER 1

INTRODUCTION

SECTION I GENERAL INFORMATION

1-1 SCOPE

This technical manual gives instructions for Direct Support Maintenance of the Leece-Neville Alternator, 180 Amperes, Model 5520AB.

1-2 MAINTENANCE FORMS, RECORDS AND REPORTS

Department of the Army forms and procedures used for equipment maintenance will be those prescribed by DA PAM 738-750, The Army Maintenance Management System (TAMMS).

1-3 DESTRUCTION OF ARMY MATERIEL TO PREVENT ENEMY USE

Refer to TM 750-244-6 for procedures on how to destroy the Alternator.

1-4 PREPARATION FOR STORAGE OR SHIPMENT

Prepare for storage or shipment in accordance with local procedures.

1-5 REPORTING EQUIPMENT IMPROVEMENT RECOMMENDATIONS (EIR)

If your Alternator needs improvement, let us know. Send us an EIR. You, the user, are the only one who can tell us what you don't like about your equipment. Let us know why you don't like the design. Put it on a SF 368 (Quality Deficiency Report). Mail it to us at: Commander, US. Army Tank-Automotive Command, ATTN: AMSTA-QRT, Warren, MI. 48397-5000. We'll send you a reply.

SECTION II EQUIPMENT DESCRIPTION AND DATA

1-6 EQUIPMENT CHARACTERISTICS AND FEATURES

The Alternator produces alternating current that is externally rectified (altered to direct current) to charge the vehicle and equipment batteries. It consists of a Drive End Housing, Stator, Rotor, End Housing, Axial Impeller Fan, Connector Assembly and Brush Rigging Assembly containing four Brushes.

1-7 LOCATION AND DESCRIPTION OF MAJOR COMPONENTS

- 1 DRIVE END HOUSING - Holds the Drive Blocks, Bearing, Spline Shaft and Cam Assembly in place. Also used to mount Alternator to vehicle.
- 2 AIR SHROUD - Houses the Stator Assembly.
- 3 ROTOR ASSEMBLY - Rotates to generate electrical power.
- 4 END HOUSING - Retains the Rigging Brush Assembly.
- 5 AXIAL IMPELLER FAN - The cooling system.
- 6 CONNECTOR ASSEMBLY - Connects with the vehicle electrical system.
- 7 SPLINE SHAFT AND CAM ASSEMBLY - Interfaces with vehicle accessory drive shaft.
- 8 IDENTIFICATION PLATE - Shows all required data information.

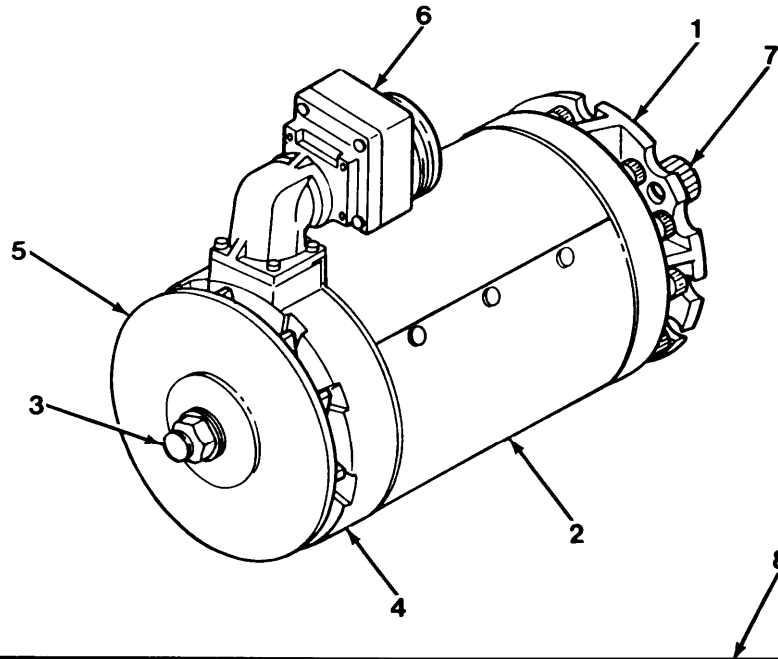

GENERATOR, ENGINE ACCESSORY			
A0015520AB L.N. TYPE NO.	12268305 ORDNANCE NO.	MILITARY STANDARO NO.	
28 VOLTS	180 AMPS	XA-20 L.N. SERIAL NO.	REVERSIBLE ROTATION
2920-01-288-0497 NATIONAL STOCK NO.		CONTRACT NO.	
LEECE-NEVILLE A PRESTOLITE ELECTRIC BUSINESS CLEVELAND, OHIO U.S.A.			

1-8 EQUIPMENT DATA

The Alternator is used on the M109A4 Self-Propelled Howitzer. The Alternator's operating ambient temperature is -65 to 165°F, and has direct drive with reversible rotation. At 2800 to 8000 rpm, the Alternator produces 28 volts and 180 amperes (nominal). The weight is 47 pounds.

1-9 SAFETY CARE AND HANDLING

Avoid dropping the Alternator so as not to harm yourself or damage the equipment. Be careful not to damage any threads when removing or installing the Alternator. Be careful not to damage the threads or pins of the connector assembly.

WARNING

Energized systems and equipment can burn you. If **MASTER SWITCH** is **ON**, electrical system and equipment will be energized. Make sure **MASTER SWITCH** is **OFF** when you work on electrical systems or equipment.

CHAPTER 2

ALTERNATOR TROUBLESHOOTING

SECTION I REPAIR PARTS, SPECIAL TOOLS, TEST MEASUREMENT AND DIAGNOSTIC EQUIPMENT (TMDE) AND SUPPORT EQUIPMENT

2-1 COMMON TOOLS AND EQUIPMENT

For authorized common tools and equipment, refer to the Modified Table of Organization and Equipment (MTOE) applicable to your unit.

2-2 SPECIAL TOOLS

500-amp test stand.

2-3 REPAIR PARTS

Repair parts are listed in Appendix B of this manual.

SECTION II TROUBLESHOOTING

2-4 PURPOSE

This chapter contains detailed troubleshooting information and procedures for locating and correcting malfunctions in the various component parts of the Alternator.

2-5 TROUBLESHOOTING PROCEDURES

a After the Alternator has been received, inspect the Alternator as follows:

- 1 Check if spline shaft turns. If it does not, check if drive end housing has been seated correctly. Check bearings and make sure there is no obstruction between spline shaft and air shroud.
- 2 Grasp spline shaft and see if it can be moved up or down, or to either side. If spline shaft does move, remove and replace worn components as required (ref Chapter 3, Disassembly Step 6).
- 3 Check pins that they are not burned, bent or broken, or pushed back into jumper connector (ref Chapter 3, Disassembly Step 19). Replace if burned, bent or broken, and pull back into proper position if pushed back.

2-5 TROUBLESHOOTING PROCEDURES (cont.)

b Perform the test stand procedures in accordance with Appendix D.

c Inspect the Alternator as follows:

- 1 Check for missing lockwashers, and missing or loose screws. Check all parts for security of attachment. Replace missing hardware and tighten loose parts.
- 2 Check leads on brushes that they are not broken, cracked, frayed or oil soaked. For removal, refer to Chapter 3, Disassembly Step 12.
- 3 Replace drive blocks if cracked, worn or warped.
- 4 Replace rotor assembly if cracked. Replace rotor assembly if there is a chipped or scratched area too deep to be sanded with an abrasive crocus cloth (ref Appendix C, Item Number 1).
- 5 Remove bearings (ref Chapter 3, Disassembly Steps 10 and 14). Check for cracks or wear. Replace if necessary (ref TM 9-214).
- 6 Replace terminal leads if burned, bent or broken (ref Chapter 3, Disassembly Step 12).

d Perform the following multimeter tests:

- 1 Place one multimeter lead on brush (A) and one multimeter lead on terminal (B). Check for continuity. If the circuit is open, repair or replace brush assembly.

Follow this procedure for all four brushes.

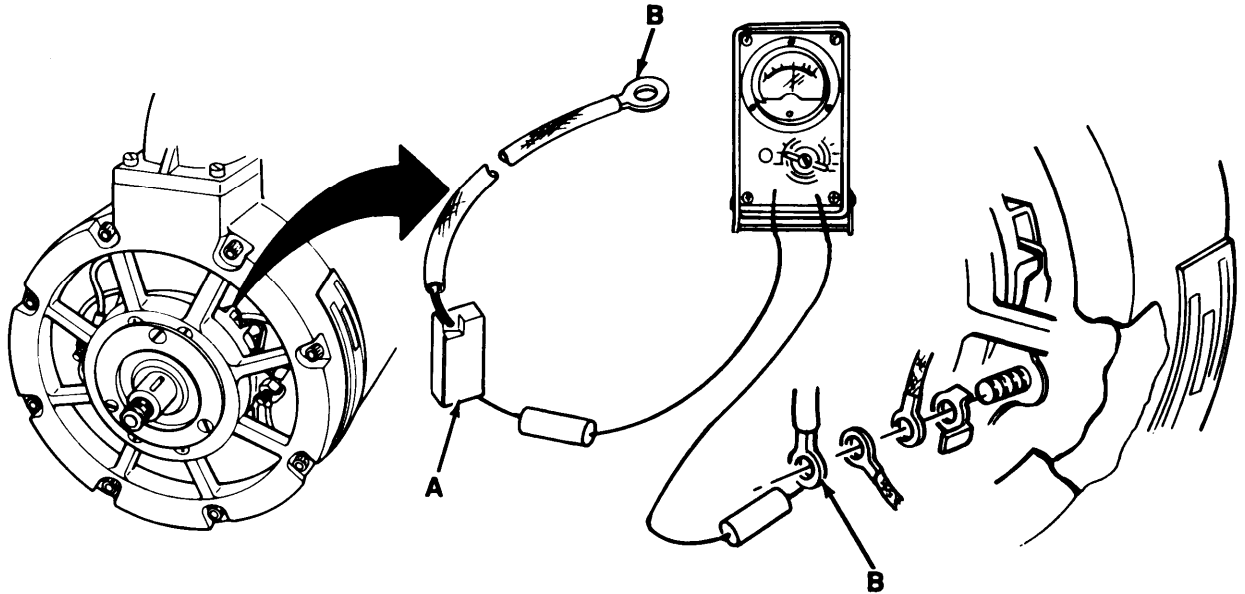

- 2 Place one multimeter lead on pin "A" and one multimeter lead on terminal (A). Check for continuity. If the circuit is open, repair or replace pin and lead assembly as required.

Follow this procedure to check pin "C" and terminal (C).

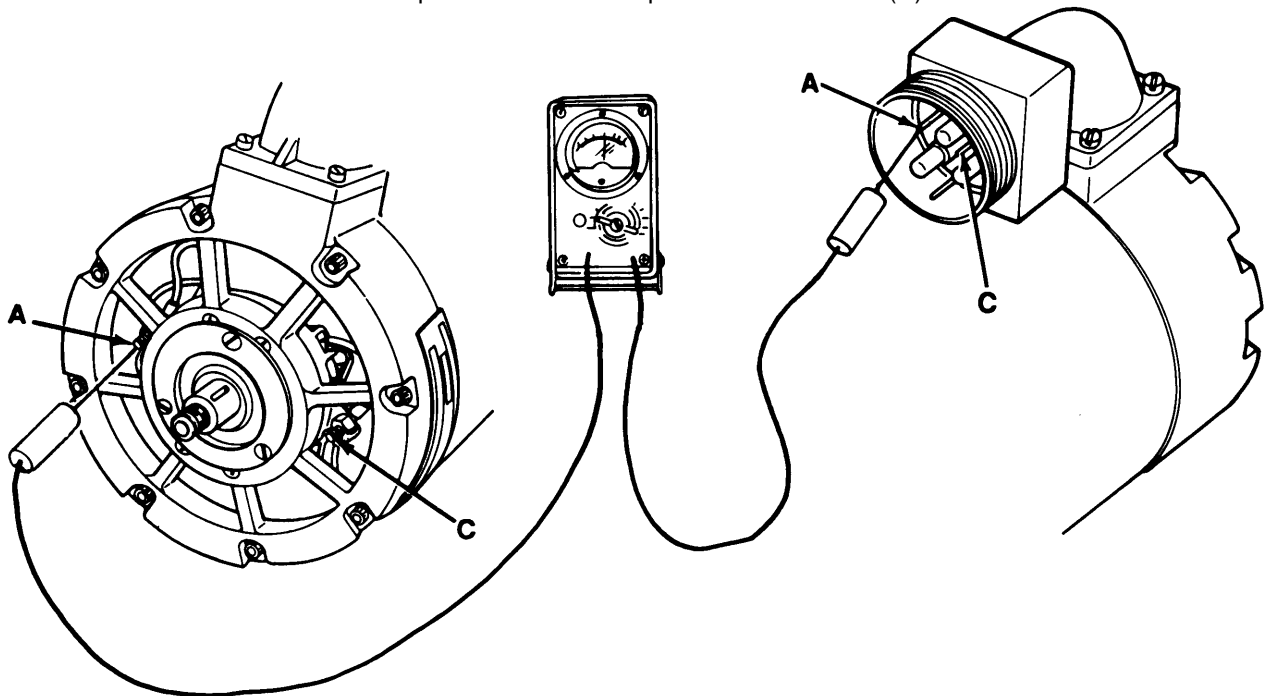

2-5 TROUBLESHOOTING PROCEDURES (cont.)

- 3 Place one multimeter lead on pin "F" and one multimeter lead on point "A" (stator assembly). Check for continuity. If circuit is open, repair or replace pin as required.

Follow above procedure to check pin "D," and then pin "B."

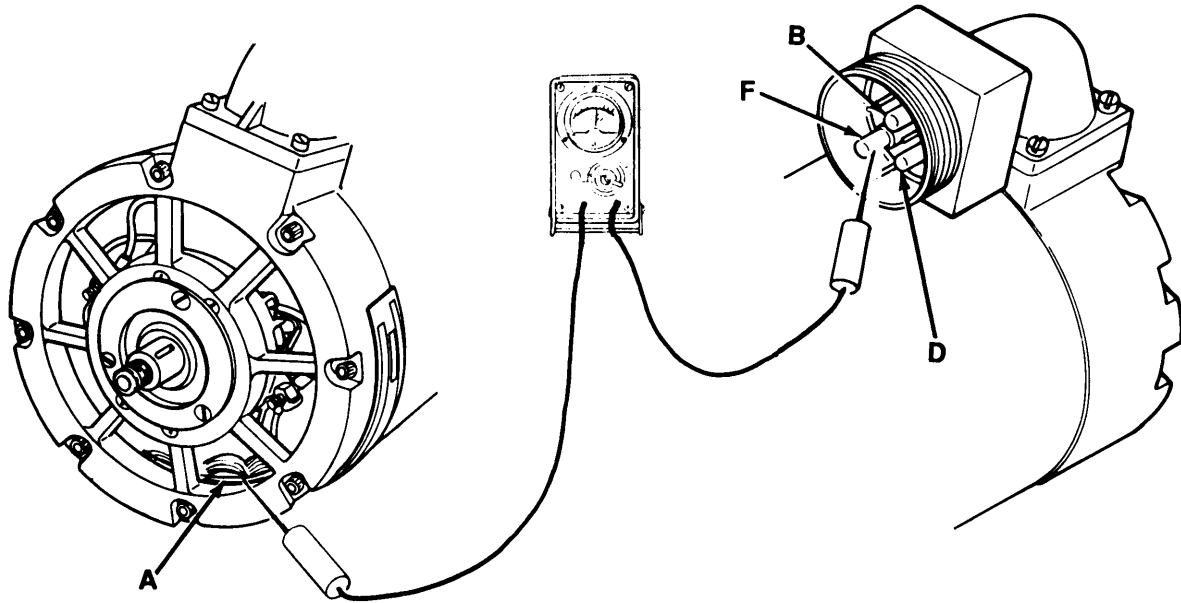

- 4 Place one multimeter lead on pin "E" and one multimeter lead on pin "D." Check for continuity. If the circuit is open, repair or replace pin "E" or "D" as required.

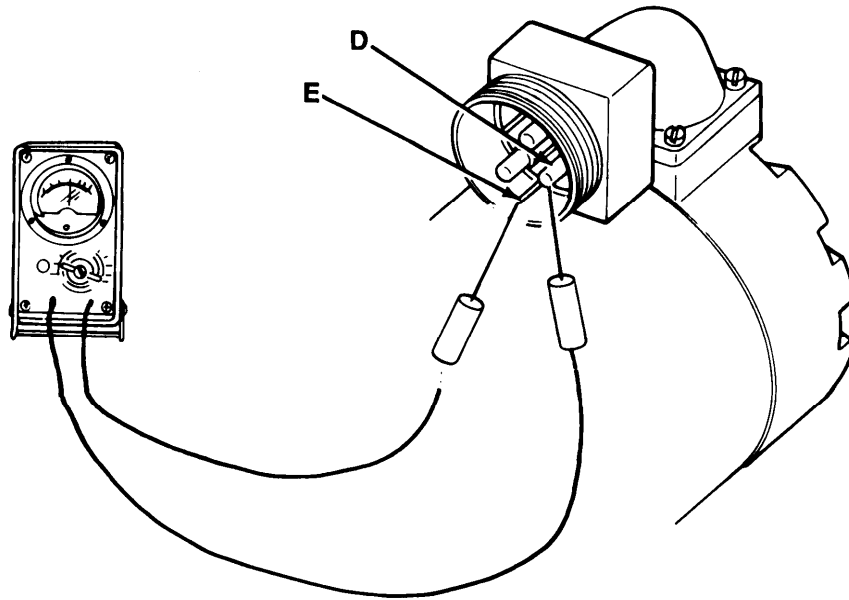

CHAPTER 3

ALTERNATOR REPAIR

3-1 PRINCIPLES OF OPERATION

The rotor assembly (1) produces lines of force. It is electrically excited by battery current passing through small brushes (2) riding on smooth slip rings. The stator assembly (3) contains the windings in which AC voltage is produced. The stator assembly is stationary, so the windings are not subjected to centrifugal force. The current is delivered at the connector assembly (4).

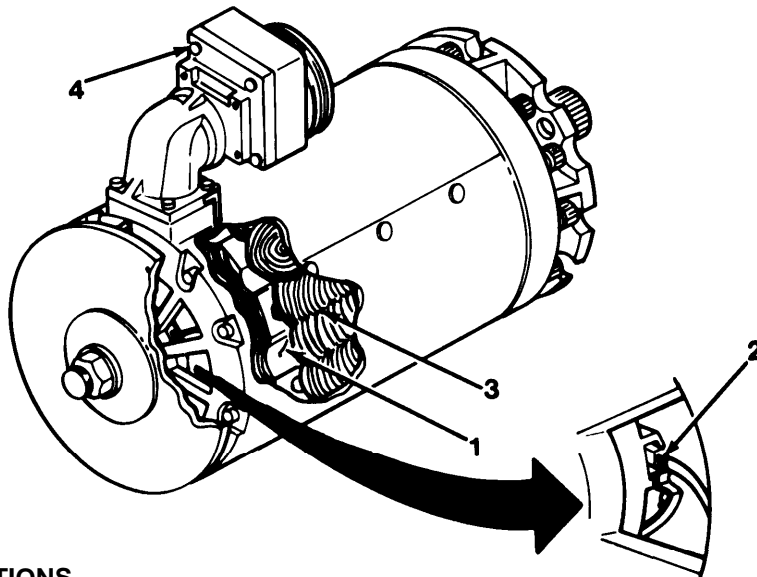

3-2 GENERAL INSTRUCTIONS

The procedures discussed in this chapter cover disassembly, inspection and assembly of the Alternator.

Disassemble only to the point required to inspect, clean and replace the damaged component(s). Exercise good judgment in following the overall disassembly procedures only to the extent required.

3-2 GENERAL INSTRUCTIONS (cont.)

During disassembly, tag critical parts such as bearings and electrical leads to facilitate reassembly.

CAUTION

Never mark bearing surfaces.

During assembly, sub-assemblies should be assembled first, combined into major components where possible and then installed to form a complete component.

3-3 REPLACEMENT OF PARTS

Unserviceable and irreparable assemblies will be broken down into issue and serviceable parts will be returned to stock. Parts or assemblies which cannot be repaired, selective-fitted, or reclaimed to the standards contained in this manual will be salvaged and new parts used to replace them.

When assembling components and assemblies, replace damaged keys with new ones, if possible. Screws, washers and nuts that are loose or damaged must be tightened or replaced.

Gaskets, packings, preformed packings, seals, lockwashers, locknuts, cotter pins and spring pins must be replaced. Bushings must be replaced only if removed.

Springs must be replaced if broken, kinked, cracked or do not conform to standards specified in repair data.

Reconditioning of the old part is necessary if a required part is not available. Such parts should be inspected carefully after reconditioning to determine their suitability and probable service life. Replacement parts should be requisitioned immediately.

3-4 BALL AND ROLLER BEARINGS

Refer to TM 9-214 for cleaning, inspection and lubrication of bearings, and instructions for evaluation of bearing life.

3-5 REMOVING BURRS, SCRATCHES AND RAISED METAL

Use fine mill file, soft stone or crocus cloth dipped in mineral spirits, paint thinner or dry cleaning solvent to remove burrs, scratches or raised metal.

When filing aluminum, clean file often with steel file brush to avoid lodging file with aluminum particles which will gouge work surface.

3-6 REPAIRING DAMAGED THREADS

When determined feasible by inspection, damaged threads should be repaired by retapping, use of a thread die or by “chasing” on a lathe.

Tapped holes for screw thread inserts that have mutilated threads may be repaired by:

- a Drilling and tapping hole oversize and installing large inserts.
- b Filling tapped hole by welding and redrilling and tapping hole to original size.

3-7 ALTERNATOR CLEANING INSTRUCTIONS

- a Clean exterior surfaces of the Alternator as follows:

WARNING

Dry cleaning solvent P-D-680 is **toxic** and **flammable**. Wear protective goggles, gloves and apron, and use only in a well ventilated area. Avoid contact with skin, eyes, and clothes and don't breathe vapors. **Do not** use near open flame or excessive heat. The flash point is 100-138°F (38-59°C). If you become dizzy while using cleaning solvent, get fresh air immediately and get medical aid. If contact with eyes is made, wash your eyes with water and get medical aid immediately.

WARNING

Air pressure in excess of 10 psi (69 kPa) can injure personnel. **Do not** direct pressurized air at yourself or others. Always wear goggles.

- 1 Clean exterior surfaces of the Alternator with a cloth dipped in a dry cleaning solvent (ref Appendix C, Item Number 2). Dry thoroughly with compressed air or a dry cloth.
- 2 Except where special cleaning procedures are given for a component or part, clean all metal components and parts with dry cleaning solvent, and use warm soapy water for all other parts. Dry thoroughly with compressed air.

3-8 ALTERNATOR REPAIR

THIS TASK COVERS:

- a Disassembly b Inspection c Assembly
-

INITIAL SET-UP:

- Tools
#1 Supplemental Tool Kit (SC 4910-95-CL-A73)
Universal Gear Puller
-

a Disassembly

- 1 Scribe a mark, for realignment, on slip ring (S. R.) end housing (1) and stator assembly (2). Remove lock nut (3) and shaft washer (4), and slide axial impeller fan (5) off shaft (6).

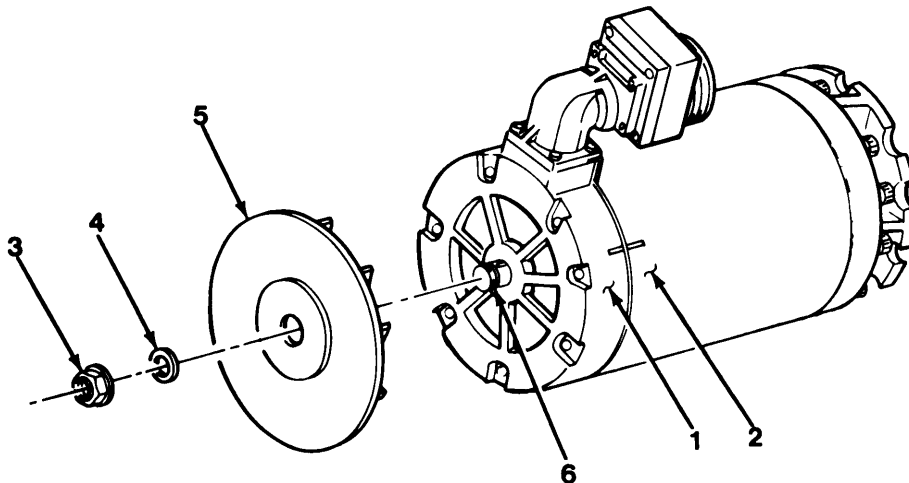

- 2 Remove woodruff key (7) from shaft (6).
- 3 Lift four brushes (8) part way out of brush rigging assembly (9).

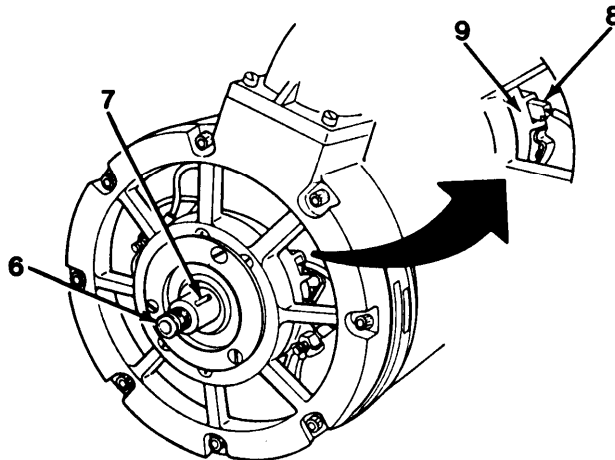

- 4 Scribe a mark, for realignment, on stator assembly (2) and drive end housing (10).
- 5 Open tabs on 6 tabbed lockwashers (11) and remove 12 screws (12), 12 lockwashers (13), 6 tabbed lockwashers (11) and cover plate (14).

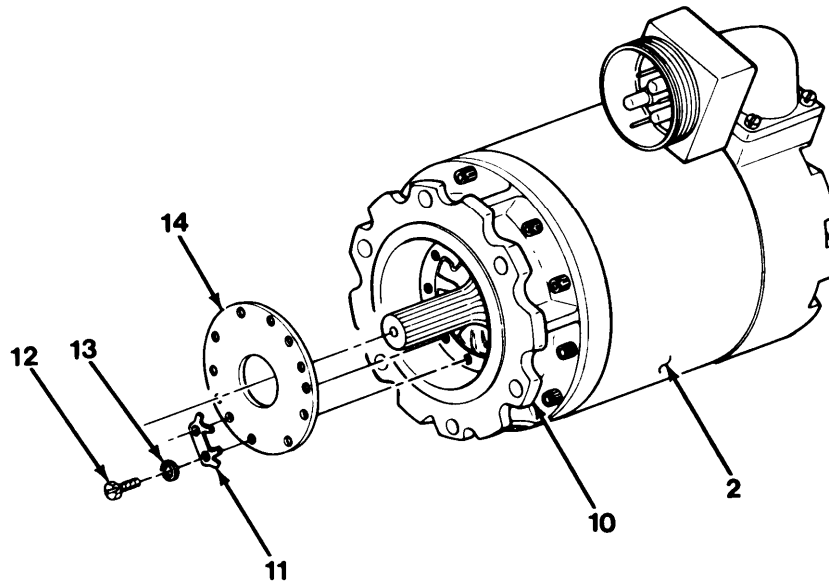

- 6 Remove two drive blocks (15), spline shaft and cam assembly (16) and snap ring (17).
- 7 Remove 12 socket head screws (18) and 12 lockwashers (19).
- 8 Remove drive end housing (10) and block holder assembly (20) with key (21).

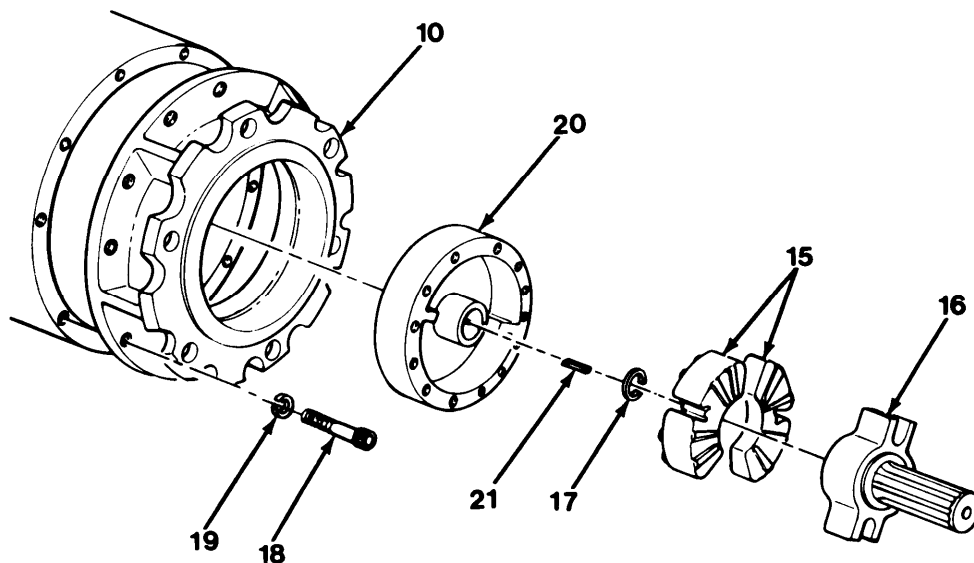

3-8 ALTERNATOR REPAIR (cont.)

a Disassembly (cont.)

- 9 Remove rotor assembly (22) from stator assembly (2).
- 10 Using a Universal Gear Puller, remove bearing (23) from rotor assembly (22).

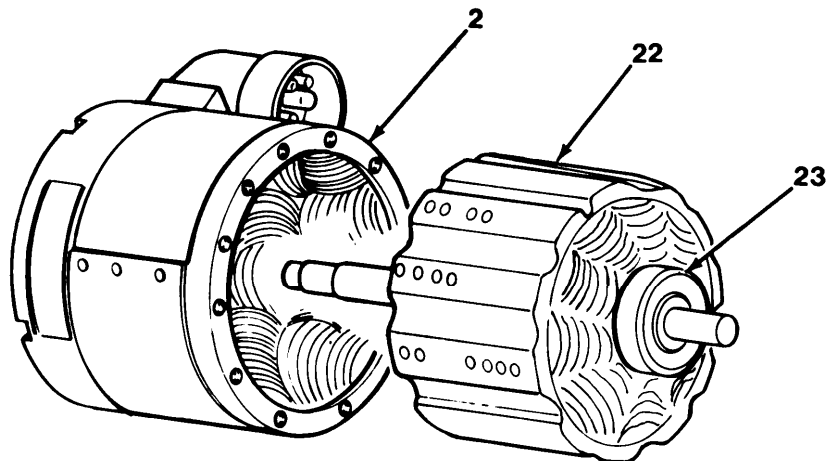

- 11 Remove and discard three screws (24) and remove bearing retainer (25).
- 12 Open tab of tabbed lockwasher (29). Remove nut (26), lockwasher (27), terminal lead (28), two brush leads (8) and tabbed lockwasher (29). Repeat for opposite stud.
- 13 Remove four brush assemblies (8).

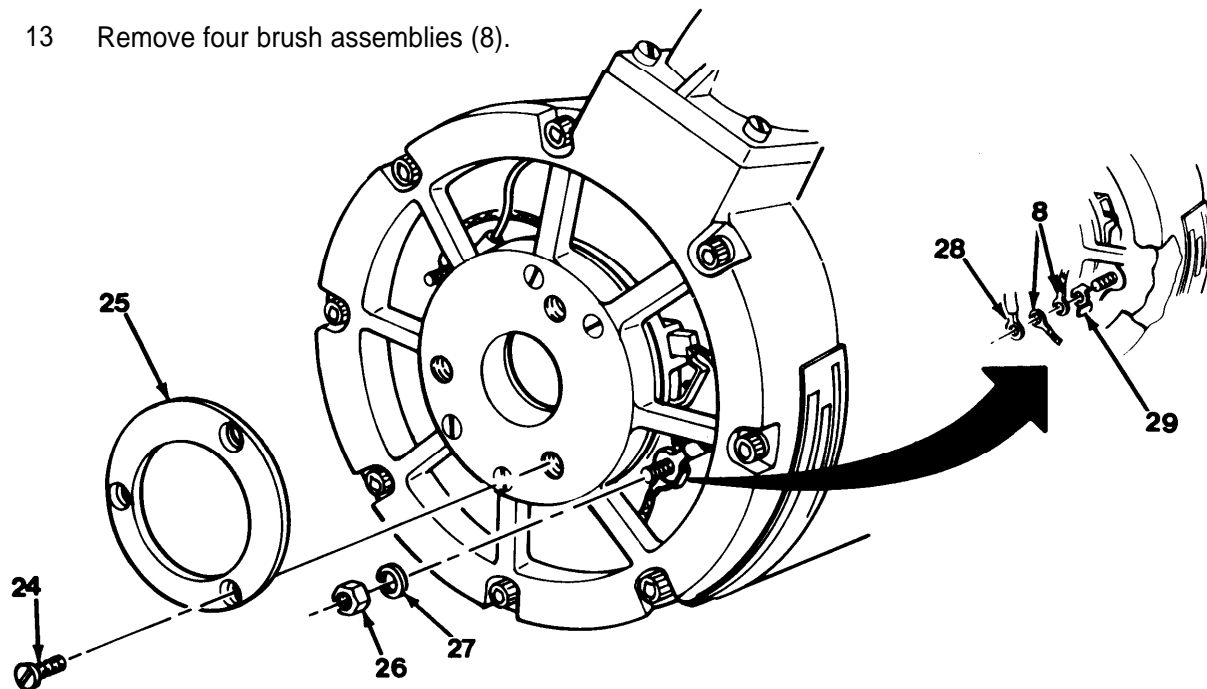

- 14 Remove four screws (30). From inside stator assembly (2), remove brush rigging assembly (31) and bearing retainer (32). Using a Bearing Puller with Slide Hammer, remove bearing (33).

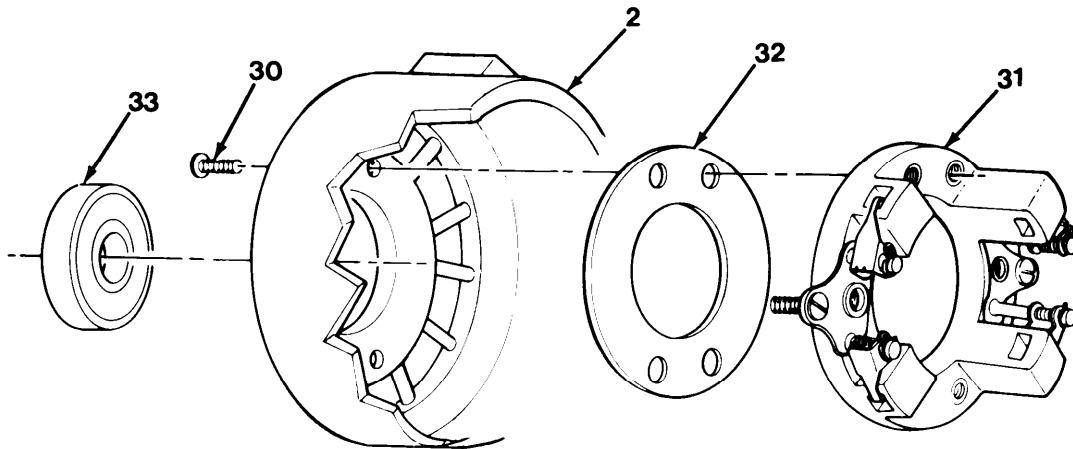

- 15 Remove four screws (34) and four lockwashers (35) from connector assembly (41).
- 16 Remove two screws (36), two lockwashers (37), two screws (38) and two lockwashers (37) from jumper connector (39).
- 17 Remove terminal cover (40).
- 18 Remove seven screws (42) and seven lockwashers (43) from S.R. end housing (1). Separate the S.R. end housing (1) from stator assembly (2).
- 19 Pull jumper connector (39) back away from stator assembly (2) exposing all wires.

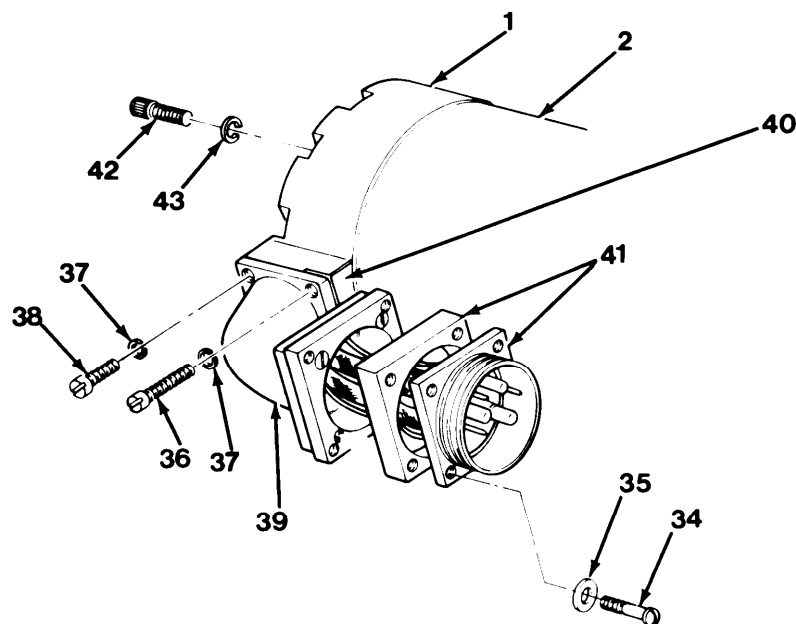

3-8 ALTERNATOR REPAIR (cont.)

a Disassembly (cont.)

- 20 Remove pins from connector assembly (41). Pins "A" and "B" are connected to terminal leads (44).

NOTE

Terminal leads, wires and pins, including pin "C" with copper lead, can be removed and replaced if necessary (ref Assembly Step 1).

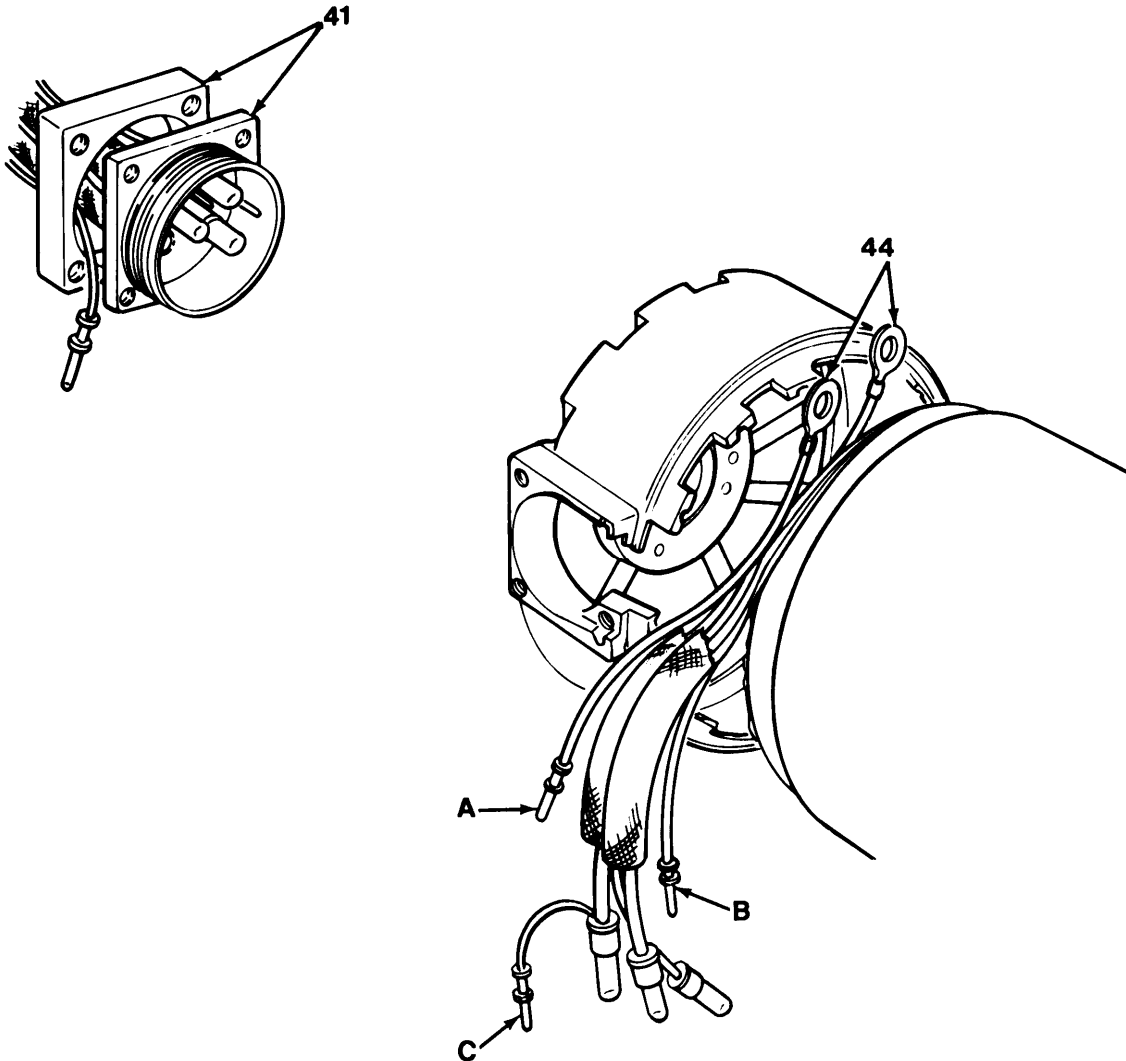

b Inspection

1 Inspect axial impeller fan (5) and stator assembly (2) for cracks or damage.

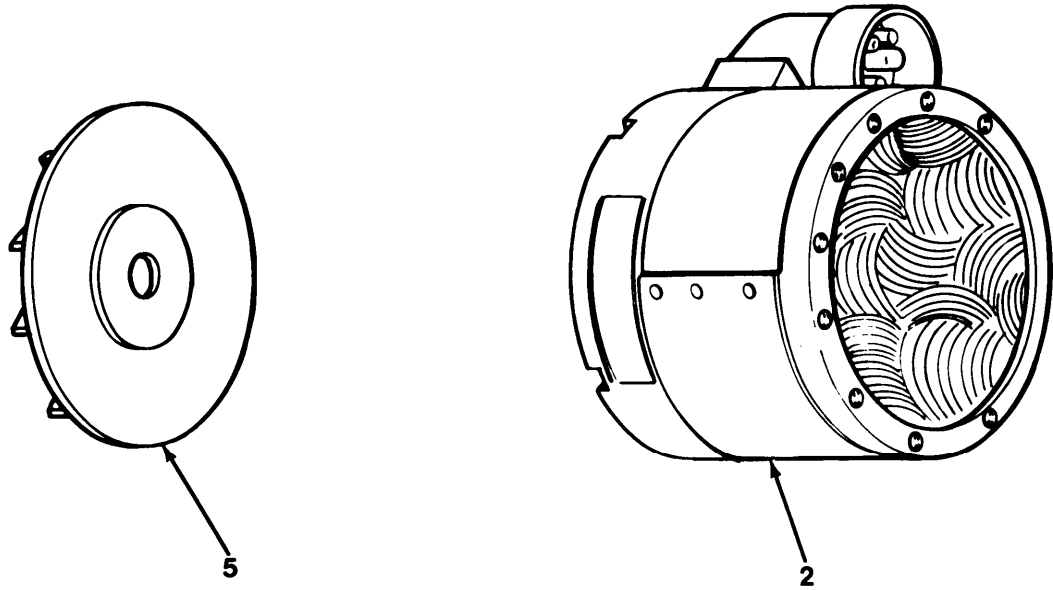

2 Inspect drive blocks (15) for cracks, warping or splits.

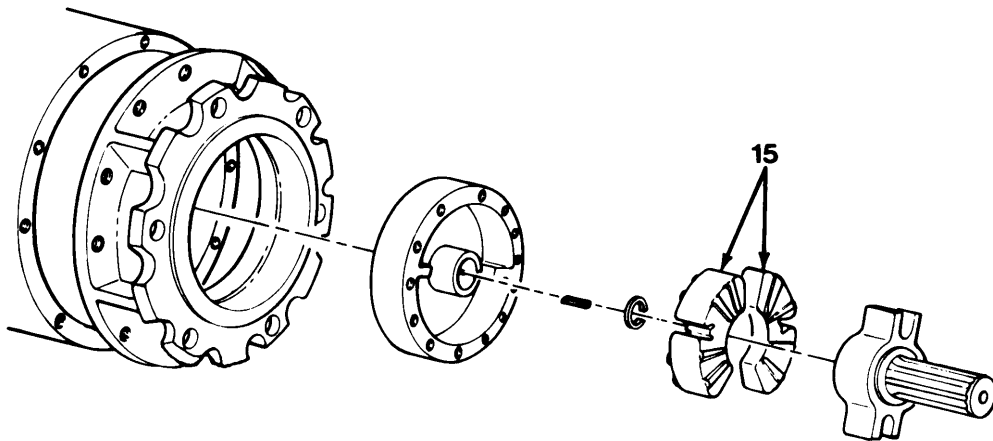

3-8 ALTERNATOR REPAIR (cont.)

b Inspection (cont.)

- 3 Inspect spline shaft and cam assembly (16) for cracks or damage, especially in splined area.

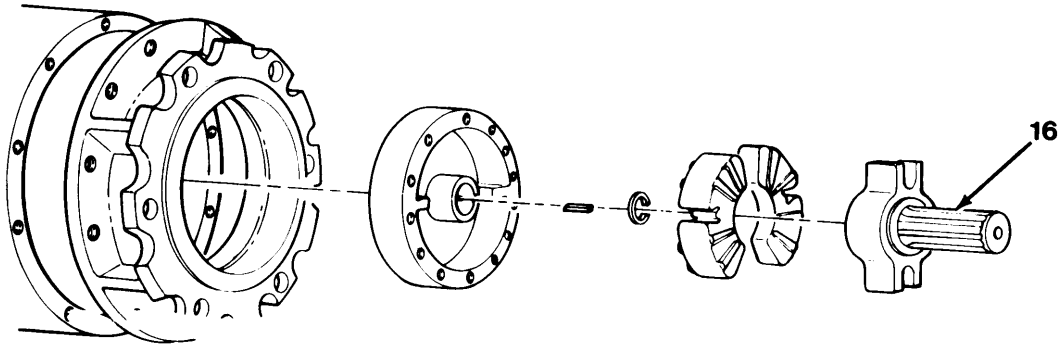

- 4 Inspect bearings (23) and (33) (ref Table 3-1, page 3-13 and Table 3-2, page 3-14). Inspect rotor assembly (22) for deep scratches on surface (slight marks can be removed with an abrasive crocus cloth [ref Appendix C, Item Number 1]).

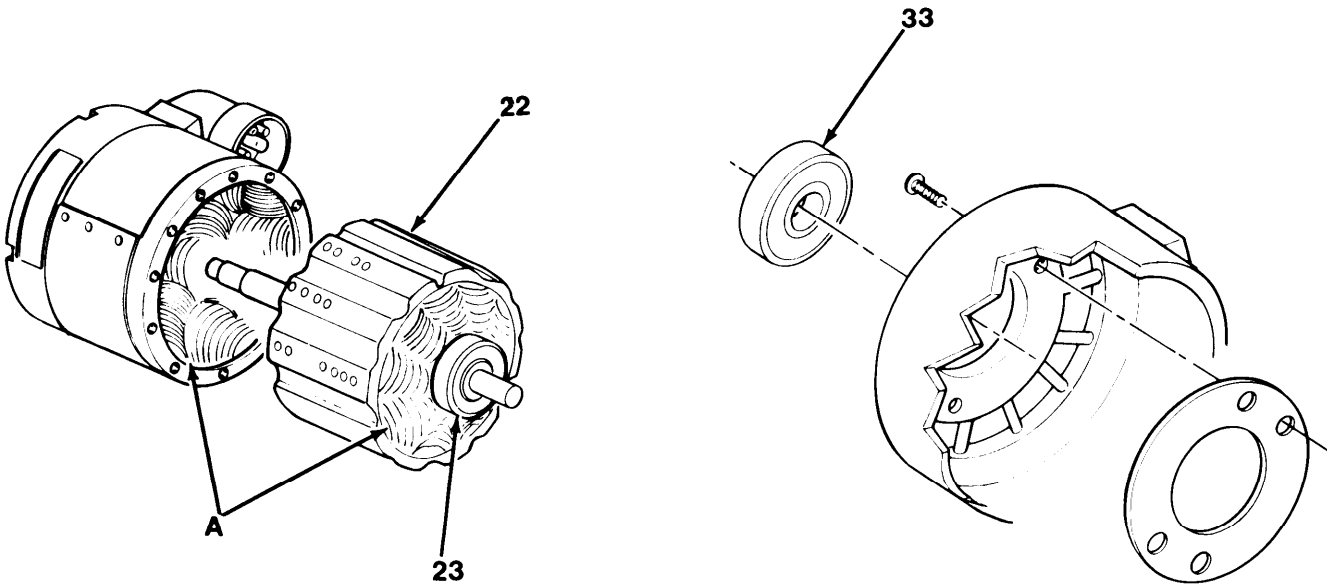

- 5 Inspect rotor assembly as follows:
- A Check that rotor shaft (45) is straight and has no burred or stripped threads.
 - B Check that rotor (46) has no grounds by touching one test lead of multimeter to rotor shaft (45) and the other test lead to one slip ring (47). Ohmmeter reading must be more than 10,000 ohms. If ohmmeter reading is not more than 10,000 ohms, Alternator is irreparable.
 - C Repeat step B for other slip ring (47).
 - D Check resistance of slip rings (47) by touching test leads of multimeter to each slip ring. Resistance must be between 1.8-2.0 ohms. If resistance is not within limits, Alternator is irreparable.
 - E Check runout of slip rings (47) (ref Table 3-1, page 3-13).

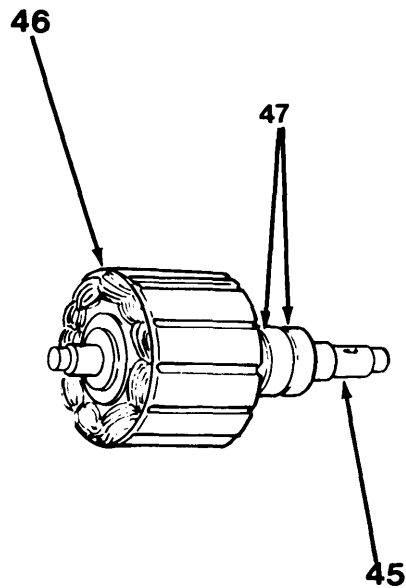

3-8 ALTERNATOR REPAIR (cont.)

b Inspection (cont.)

- 6 Inspect brush assemblies (8) for frays or burns. Be sure brushes have not worn down further than measurement required (shown in illustration below). Inspect brush rigging assembly (31) for cracks, loose springs or any visible damage.

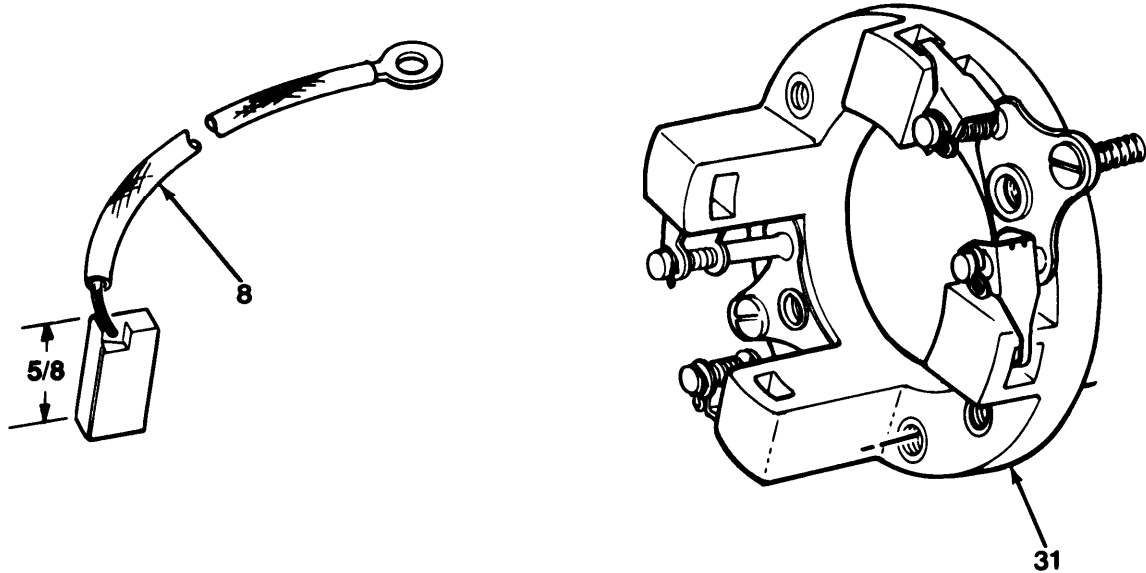

- 7 Inspect connector assembly (41) for burned, bent or broken pins.

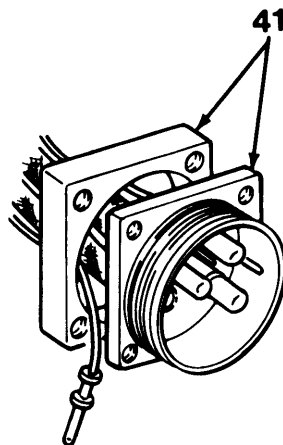

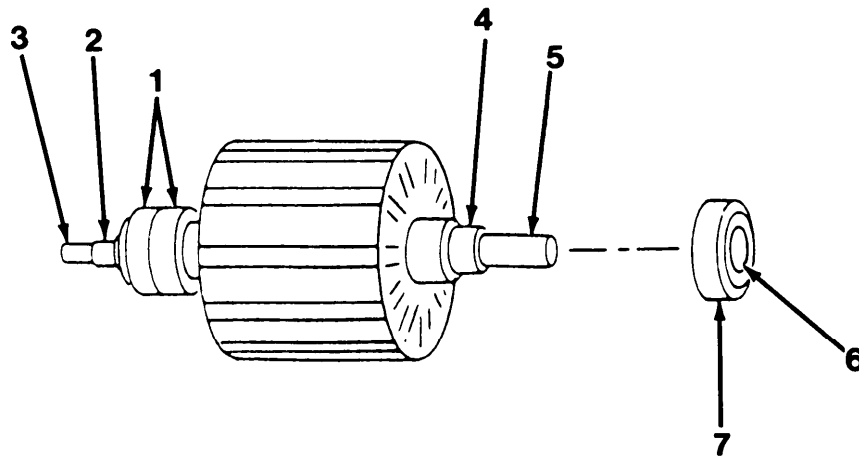

Table 3-1. Drive End Housing and Rotor Assembly Wear Limits

Index Number	Item/Point of Measurement	Size and Fit of New Parts (inches)	Wear Limits (inches)
1	Outside diameter of slip rings	1.8430-1.8530	1.7500
2	Outside diameter of shaft at fan bearing seat	0.7874-0.7878	None
3	Outside diameter of shaft at fan hub seat	0.6250-0.6255	None
4	Outside diameter of shaft at drive end housing bearing seat	0.9842-0.9846	None
5	Outside diameter of shaft at drive end housing	0.6245-0.6250	None
6	Inside diameter of drive end housing bearing	0.9839-0.9843	None
7	Outside diameter of drive end housing bearing	2.0467-2.0472	None

3-8 ALTERNATOR REPAIR (cont.)

b Inspection (cont.)

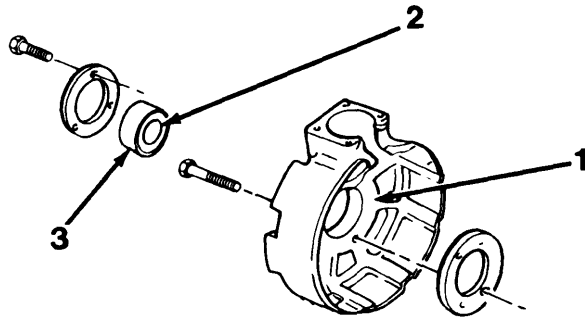

Table 3-2. S.R. End Housing Assembly Wear Limits

Index Number	Item/Point of Measurement	Size and Fit of New Parts (inches)	Wear Limits (inches)
1	Inside diameter of S.R. end housing bearing bore	1.8497-1.8501	None
2	Inside diameter of S.R. end housing bearing	0.7870-0.7874	None
3	Outside diameter of S.R. end housing bearing	1.8499-1.8504	None

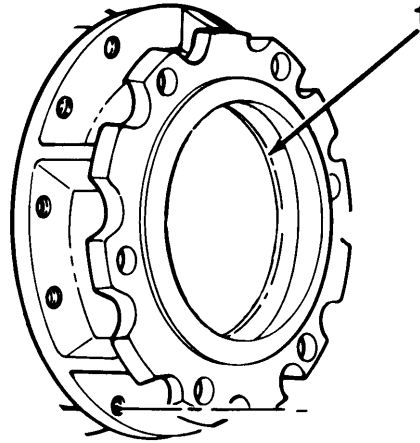

Table 3-3. Drive End Housing (Models 5504AA & 5504AB) Wear Limits

Index Number	Item/Point of Measurement	Size and Fit of New Parts (inches)	Wear Limits (inches)
1	Inside diameter of drive end housing bearing bore	2.0465-2.0468	None

3-8 ALTERNATOR REPAIR (cont.)

c Assembly

- 1 Pins must be soldered to their leads (ref TB SIGm 222). Install pins (44) into connector assembly(41).
- 2 Install bearing (33) into S.R. end housing (1). Align bearing retainer (32) and brush rigging retainer assembly (31) from inside S.R. end housing (1). Secure in place with four screws (30).

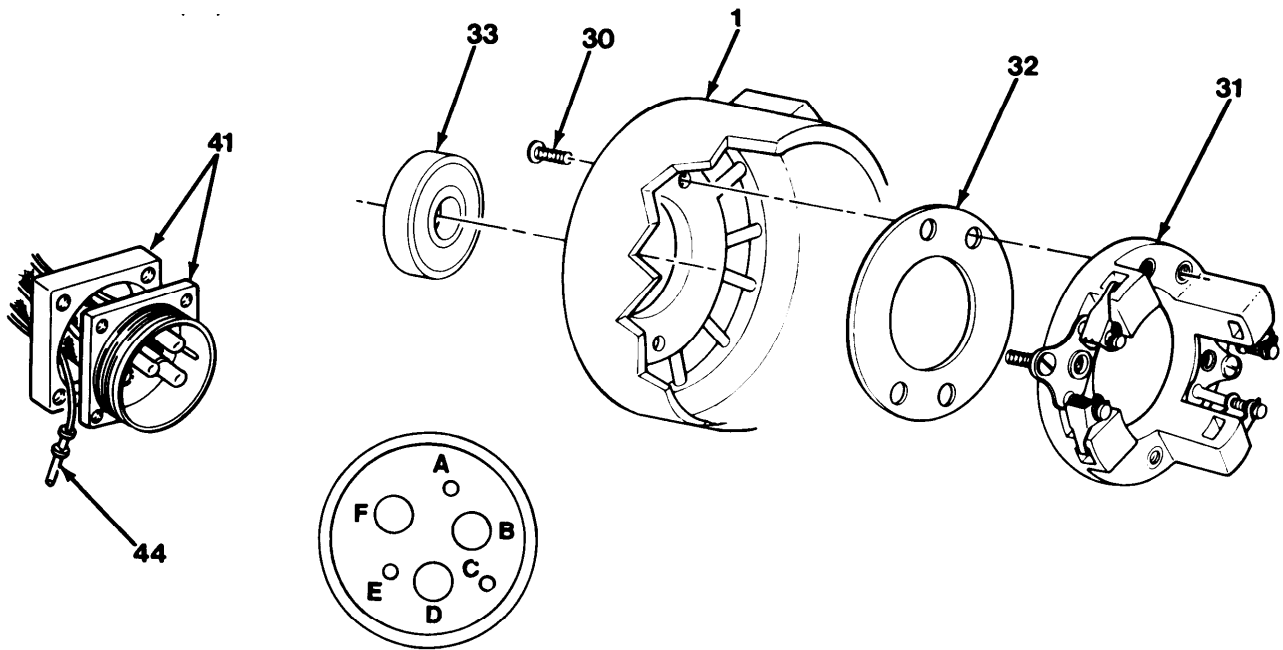

- 3 Align S.R. end housing (1) to stator assembly (2) using previously scribed marks. Secure in place with seven screws (42) and seven lockwashers (43).

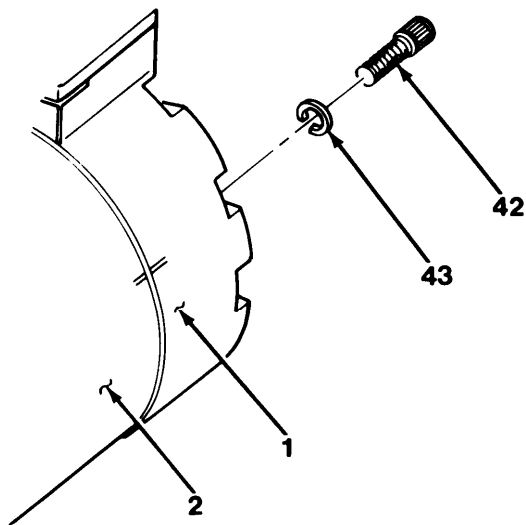

- 4 Insert terminal cover (40) and pull jumper connector (39) into place against S.R. end housing (1). Secure in place with two screws (36), two lockwashers (37), two screws (38) and two lockwashers (37).
- 5 Align jumper connector (39) and connector assembly (41). Secure in place with four lockwashers (35) and four screws (34).

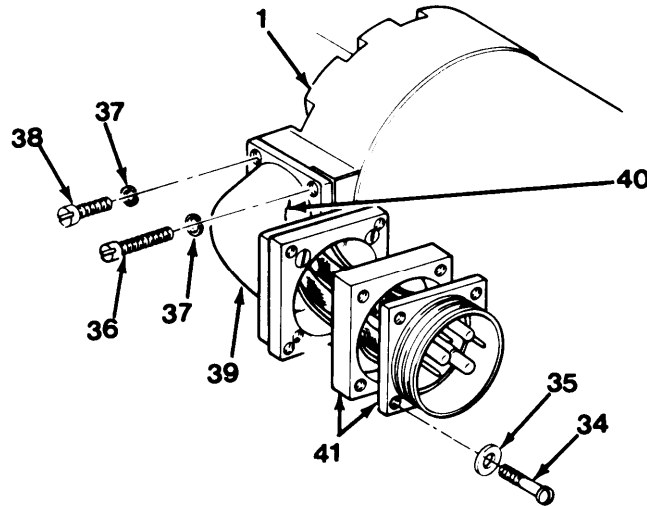

NOTE

Install brush lead away from brush spring.

- 6 Insert four brushes (8) partially into brush rigging assembly (31). Install tabbed lockwasher (29), two brush leads (8), terminal lead (28), lockwasher (27) and nut (26) onto existing stud of brush rigging assembly (31). Close tabbed lockwasher over nut. Repeat for opposite side.
- 7 Place bearing retainer (25) onto end of S.R. end housing (1). Secure in place with three screws (24).

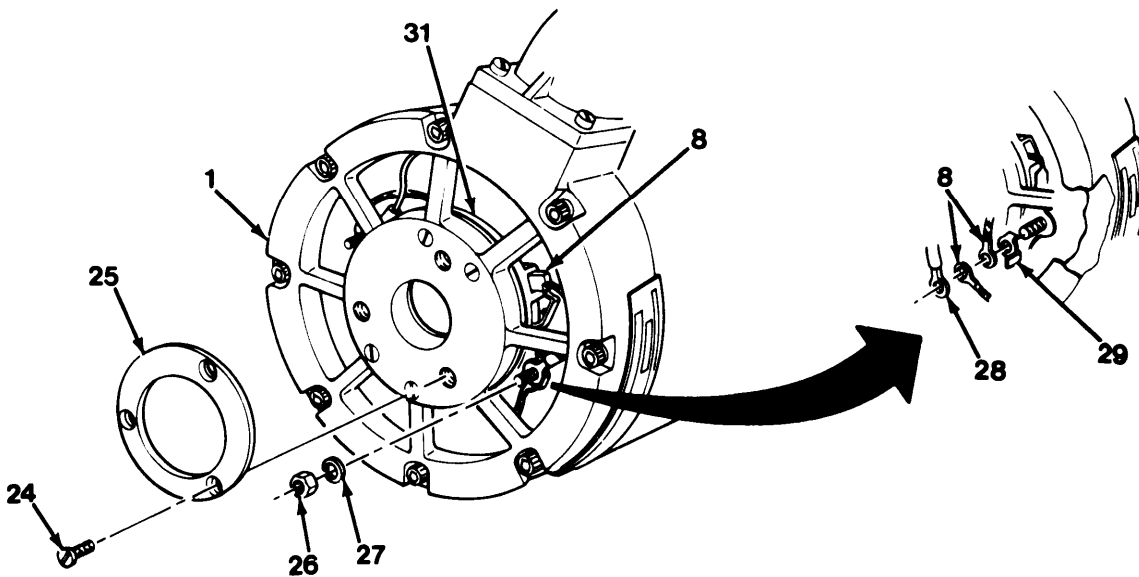

3-8 ALTERNATOR REPAIR (cont.)

c Assembly (cont.)

- 8 Install bearing (23) onto rotor assembly (22).
- 9 Install rotor assembly (22) into stator assembly (2).

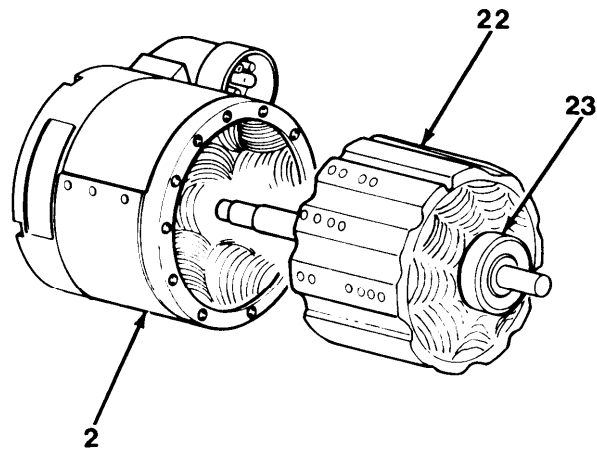

- 10 Press drive end housing (10) onto rotor assembly (22) and align drive end housing (10) to stator assembly (2) using previously scribed marks. Secure in place with 12 socket head screws (18) and 12 lockwashers (19).

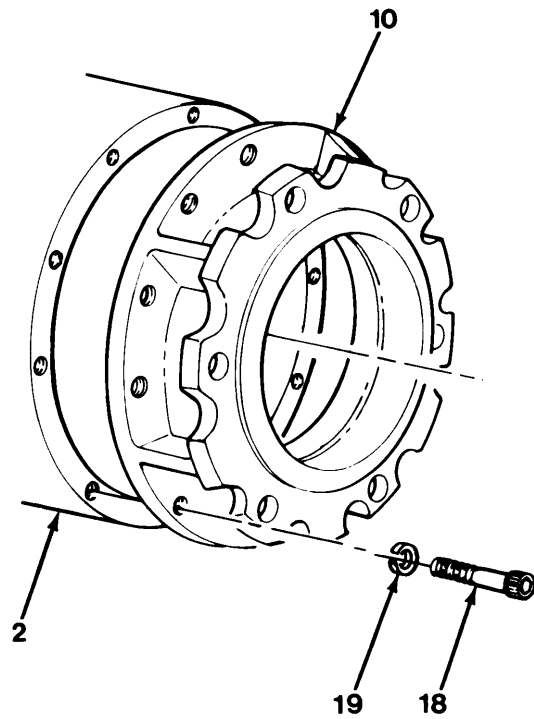

- 11 Push four brushes (8) into position on brush rigging assembly (9). Replace woodruff key (7) into shaft (6).
- 12 Slide axial impeller fan (5) onto shaft (6) and secure in place with shaft washer (4) and lock nut (3).

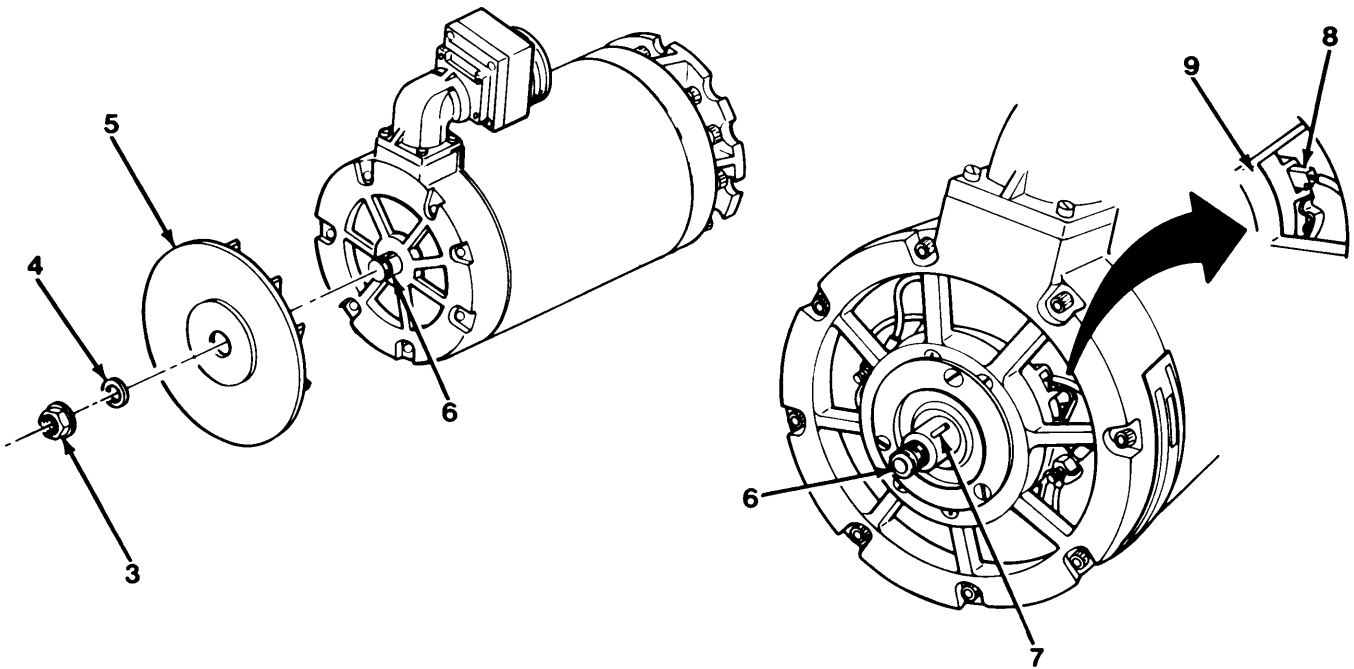

- 13 Install block holder assembly (20), key (21) and snap ring (17).
- 14 Insert spline shaft and cam assembly (16) and drive blocks (15) into block holder assembly (20).

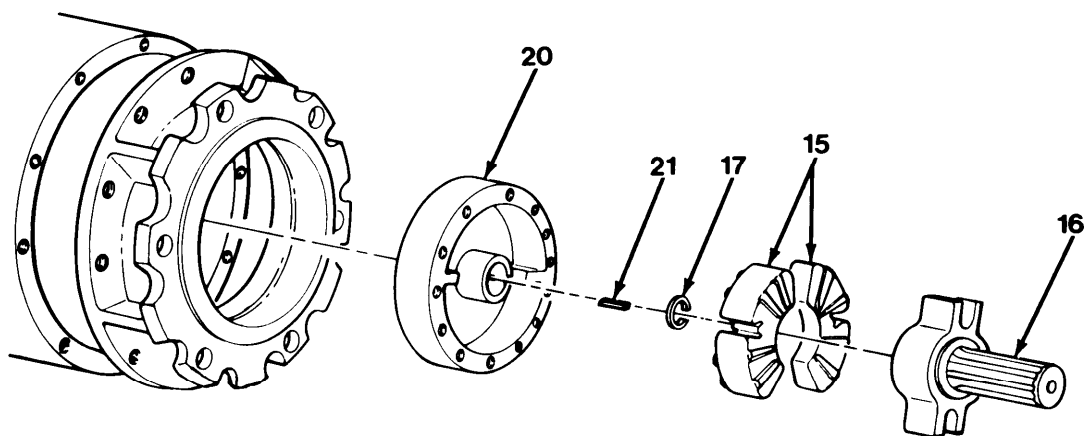

3-8 ALTERNATOR REPAIR (cont.)

- 15 Slide cover plate (14) onto spline shaft and cam assembly (16) and secure with 6 tabbed lockwashers (11), 12 lockwashers (13) and 12 screws (12). Torque 12 screws (12) to 10 lb-in.
- 16 Close tabbed lockwashers (11) around screws (12).

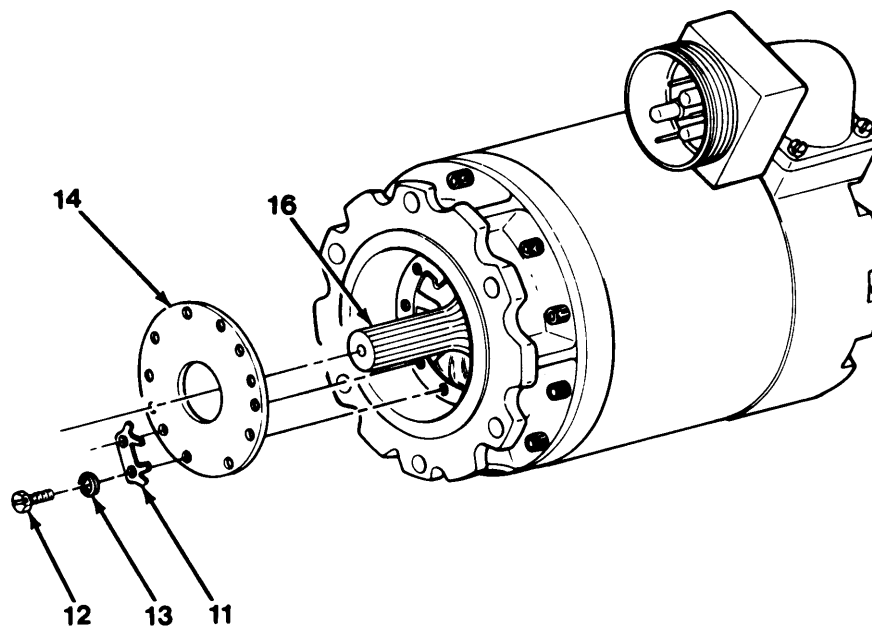

- 17 Perform the test stand procedures in accordance with Appendix D.

APPENDIX A

REFERENCES

A-1 GENERAL

This appendix contains a list of references which appear in this technical manual.

A-2 FORMS

- Quality Deficiency Report. SF 368
- Recommended Changes to Equipment Publications. DA FORM 2028-2

A-3 TECHNICAL MANUALS

- Inspection, Care and Maintenance of Antifriction Bearings. TM 9-214

- Operator and Organizational Maintenance Manual (Including Repair Parts and Special Tools List): Test Stand, Automotive Generator, Alternator and Starter, Floor Mounted, 10 to 50V 500 Amp. DC and 25 to 50V, 100 to 400 Amp, AC, Testing Ranges W/8000 to 12000 RPM, 22 1/2 HP, 220/440V, 60 Cycle, 3 Phase, Dual Head Vari-Drive Assembly (Sun Electric Corporation Model AGT-9 and AGT-9A) (4910-00-767-0218). TM 9-4910-485-12

- Operator's and Organizational Maintenance Manual for Test Stand, Automotive Generator, Alternator Starter and Associated Equipment, Model GASR500 (4910-01-041-8161) (PN 7458-4).. TM 9-4910-663-12

- The Army Maintenance Management System (TAMMS). DA PAM 738-750

- Painting Instructions for Field Use. TM 43-0139

- Equipment Improvement Report and Maintenance Summary for TARCOM Equipment. TM 43-0143

- Organizational Maintenance Manual for Hull, Powerplant, Drive Control, Tracks, Suspension and Associated Hardware for Howitzer, Medium, Self-Propelled, 155mm M109A2 (2350-01-031-0586); M109A3 (2350-01-031-8851); and M109A4 (2350-01-277-5770). TM 9-2350 -311-20-1

- Organizational, Direct Support and General Support Maintenance Repair Parts and Special Tools List (Including Depot Maintenance Repair Parts and Special Tools) for Howitzer, Medium, Self-Propelled, 155mm M109A2 (2350-01-031-0586); M109A3 (2350-01-031-8851); and M109A4 (2350-01-277-5770) Hull. TM 9-2350-311-24P-1

- Direct Support and General Support Maintenance Manual for Hull, Suspension and Associated Components for Howitzer, Medium, Self-Propelled, 155mm M109A2 (2350-01-031-05896); M109A3 (2350-01-03108851); and M109A4 (2350-01-277-5770). TM 9-2350-311-34-1

TM 9-2920-258-30&P

A-4 TECHNICAL BULLETINS

Solder and Soldering.

TB SIG 222

APPENDIX B

DIRECT SUPPORT MAINTENANCE REPAIR PARTS AND SPECIAL TOOLS LIST

SECTION I. INTRODUCTION

1. Scope.

This RPSTL lists and authorizes spares and repair parts; special tools; special test, measurement, and diagnostic equipment (TMDE); and other special support equipment required for performance of Direct Support maintenance of the Alternator, 180 Amperes, Model 5520AB. It authorizes the requisitioning, issue, and disposition of spares, repair parts and special tools as indicated by the source, maintenance and recoverability (SMR) codes.

2. General.

In addition to Section I, Introduction, this Repair Parts and Special Tools List is divided into the following sections:

a. **Section II. Repair Parts Lists.** A list of spares and repair parts authorized by this RPSTL for use in the performance of maintenance. The list also includes parts which must be removed for replacement of the authorized parts. Parts lists are composed of functional groups in ascending alphanumeric sequence, with the parts in each group listed in ascending figure and item number sequence. Bulk materials are listed in item name sequence. Repair parts kits are listed separately in their own functional group within Section II. Repair parts for repairable special tools are also listed in this section. Items listed are shown on the associated illustration(s)/figure(s).

b. **Section III. Special Tools List.** A list of special tools, special TMDE, and other special support equipment authorized by this RPSTL (as indicated by Basis of Issue (BOI) information in DESCRIPTION AND USABLE ON CODE column) for the performance of maintenance.

c. **Section IV. Cross-reference Indexes.** A list, in National item identification number (NIIN) sequence, of all National stock numbered items appearing in the listing, followed by a list in alphanumeric sequence of all part numbers appearing in the listings. National stock numbers and part numbers are cross-referenced to each illustration figure and item number appearance. The figure and item number index lists figure and item numbers in alphanumeric sequence and cross-references NSN, FSCM and part numbers.

3. Explanation of Columns (Section II and III).

a. **ITEM NO. (Column (1)).** Indicates the number used to identify items called out in the illustration.

b. **SMR CODE (Column (2)).** The Source, Maintenance, and Recoverability (SMR) code is a 5-position code containing supply/requisitioning information, maintenance category authorization criteria, and disposition instruction, as shown in the following example:

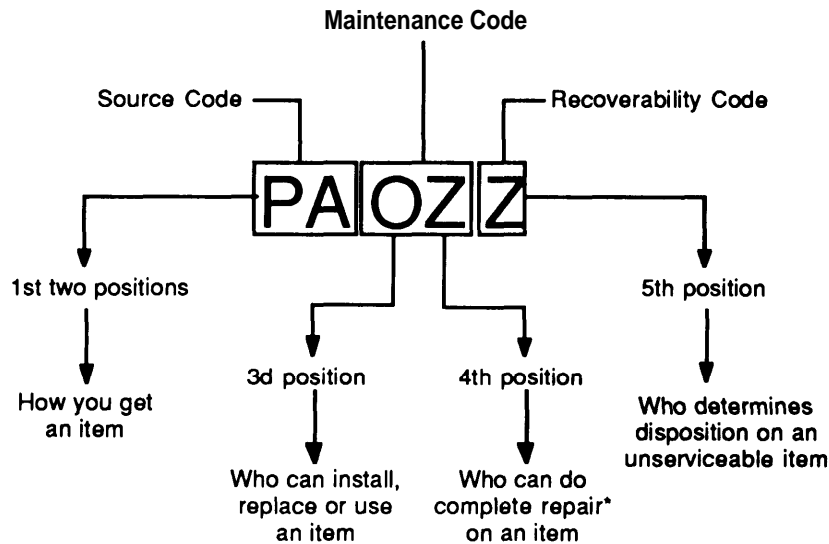

*Complete Repair: Maintenance capacity, capability, and authority to perform all corrective maintenance tasks of the "Repair" function in a use/user environment in order to restore serviceability to a failed item.

(1) Source Code. The source code tells you how to get an item needed for maintenance, repair or overhaul of an end item/equipment. Explanations of source codes follow:

Code	Explanation
PA PB PC** PD PE PF PG	Stocked items; use the applicable NSN to request/requisition items with these source codes. They are authorized to the category indicated by the code entered in the 3d position of the SMR code **NOTE: Items coded PC are subject to deterioration.
KD KF KB	Items with these codes are not to be requested/requisitioned individually. They are part of a kit which is authorized to the maintenance category indicated in the 3d position of the SMR code The complete kit must be requisitioned and applied.
MO - (Made at Unit/ AVUM Level) MF - (Made at DS/ AVIM Level) MH - (Made at GS Level) MD - (Made at Depot Level)	Items with these codes are not to be requested/requisitioned individually. They must be made from bulk material which is identified by the part number in the DESCRIPTION AND USABLE ON CODE (UOC) column and listed in the Bulk Material group of the repair parts list in this RPSTL. If the item is authorized to you by the 3d position code of the SMR code, but the source code indicates it is made at a higher level, order the item from the higher level of maintenance.
AO - (Assembled by Unit/ AVUM Level) AF - (Assembled by DS/AVIM Level)	Items with these codes are not to be requested/requisitioned individually. The parts that make up the assembled item must be requisitioned or fabricated and assembled at the level of maintenance indicated by the source code. If the 3d position code of

- AH - (Assembled by GS Category)
 AD - (Assembled by Depot)
- the SMR code authorizes you to replace the item, but the source code indicates the item is assembled at a higher level, order the item from the higher level of maintenance.
- XA - Do not requisition an "XA"-coded item. Order its next higher assembly. (Also, refer to the NOTE below.)
- XB - If an "XB" item is not available from salvage, order it using the FSCM and part number given.
- x c - Installation drawing, diagram, instruction sheet, field service drawing, that is identified by manufacturer's part number.
- XD - Item is not stocked. Order an "XD" coded item through normal supply channels using the FSCM and part number given, if no NSN is available.
- NOTE: Cannibalization or controlled exchange, when authorized, maybe used as a source of supply for items with the above source codes, except for those source coded "XA" or those aircraft support items restricted by requirements of AR 700-42.

(2) Maintenance Code. Maintenance codes tells you the level(s) of maintenance authorized to USE and REPAIR support items. The maintenance codes are entered in the third and fourth positions of the SMR Code as follows:

(a) The maintenance code entered in the third position tells you the lowest maintenance level authorized to remove, replace, and use an item. The maintenance code entered in the third position will indicate authorization to one of the following levels of maintenance.

Code	Application/Explanation
C	- Crew or Operator maintenance done within Unit maintenance.
O	- Organizational category can remove, replace, and use the item.
F	- Direct Support level can remove, replace, and use the item.
H	- General Support level can remove, replace, and use the item.
D	- Depot level can remove, replace, and use the item.

(b) The maintenance code entered in the fourth position tells whether or not the item is to be repaired and identifies the lowest maintenance level with the capability to do complete repair (i.e., perform all authorized repair functions). (NOTE: Some limited repair may be done on the item at a lower level of maintenance, if authorized by the Maintenance Allocation Chart (MAC) and SMR codes.) This position will contain one of the following maintenance codes.

Code	Application/Explanation
O	- Organizational is the lowest level that can do complete repair of the item.
F	- Direct Support is the lowest level that can do complete repair of the item.
H	- General Support is the lowest level that can do complete repair of the item.

- D - Depot is the lowest level that can do complete repair of the item.
- Z - Nonrepairable. No repair is authorized.
- B - No repair is authorized. (No parts or special tools are authorized for the maintenance of a "B" coded item.) However, the item may be reconditioned by adjusting, lubricating, etc., at the user level.

(3) RecoverabilityCode. Recoverability codes are assigned to items to indicate the disposition action on unserviceable items. The recoverability code is entered in the fifth position of the SMR Code as follows:

Recoverability Codes	Application/Explanation
Z	- Nonrepairable item. When unserviceable, condemn and dispose of the item at the level of maintenance shown in 3d position of SMR Code.
O	- Repairable item. When uneconomically repairable, condemn and dispose of the item at the Direct Support level.
F	- Repairable item. When uneconomically repairable, condemn and dispose of the item at the Direct Support level.
H	- Repairable item. When uneconomically repairable, condemn and dispose of the item at the Direct Support level.
D	- Repairable item. When beyond lower level repair capability, return to Depot. Condemnation and disposal of item not authorized below Depot level.
A	- Item requires special handling or condemnation procedures because of specific reasons (e.g., precious metal content, high dollar value, critical material, or hazardous material). Refer to appropriate manuals/directives for specific instructions.

c. FSCM (COLUMN (3)). The Federal Supply Code for Manufacturer (FSCM) is a 5-digit numeric code which is used to identify the manufacturer, distributor, or Government agency, etc., that supplies the item.

d. PART NUMBER (Column (4)). Indicates the primary number used by the manufacturer (individual, company, firm, corporation, or Government activity), which controls the design and characteristics of the item by means of its engineering drawings, specifications standards, and inspection requirements to identify an item or range of items.

NOTE: When you use a NSN to requisition an item, the item you receive may have a different part number from the part ordered.

e. DESCRIPTION AND USEABLE ON CODE (UOC (Column (5))). This column includes the following information:

- (1) The Federal item name and, when required, a minimum description to identify the item.
- (2) Items that are included in kits and sets are listed below the name of the kit or set.
- (3) Spare/repair parts that make up an assembled item are listed immediately following the assembled item line entry.

(4) Part numbers for bulk materials are referenced in this column in the line item entry for the item to be manufactured/fabricated.

(5) When the item is not used with all serial numbers of the same model, the effective serial numbers are shown on the last line(s) of the description (before UOC).

(6) The usable on code, when applicable (see paragraph).

(7) In the Special Tools List section, the basis of issue (BOI) appears as the last line(s) in the entry for each special tool, special TMDE, and other special support equipment. When density of equipments supported exceeds density spread indicated in the basis of issue, the total authorization is increased proportionately.

(8) The statement "END OF FIGURE" appears just below the last item description in Column 5 for a given figure in both Section II and Section III.

f. QTY (Column(6)). The QTY (quantity per figure column) indicates the quantity of the item used in the breakout shown on the illustration figure, which is prepared for a functional group, or an assembly. A "V" appearing in this column in lieu of a quantity indicates that the quantity is variable and the quantity may vary from application to application.

4. Explanation of Columns (Sect. IV).

a. NATIONAL STOCK NUMBER (NSN) INDEX.

(1) STOCK NUMBER column. This column lists the NSN by National item identification number (NIIN) sequence. The NIIN consists of the last nine digits of the NSN.

NSN
<hr style="width: 100%;"/>
5305-01-674-1467
NIIN

When using this column to locate an item, ignore the first 4 digits of the NSN. However, the complete NSN should be used when ordering items by stock number.

(2) FIG. column. This column lists the number of the figure where the item is identified/located. The figures are in numerical order in Section II and Section III.

(3) ITEM column. The item number identifies the item associated with the figure listed in the adjacent FIG. column. This item is also identified by the NSN listed on the same line.

b. PART NUMBER INDEX. Part numbers in this index are listed by part number in ascending alphanumeric sequence (i.e., vertical arrangement of letter and number combination which places the first letter or digit of each group in order A through Z, followed by the numbers O through 9 and each following letter or digit in like order).

(1) FSCM column. The Federal Supply Code for Manufacturer (FSCM) is a 5-digit numeric code used to identify the manufacturer, distributor, or Government agency, etc., that supplies the item.

(2) PART NUMBER column. Indicates the primary number used by the manufacturer (individual, firm, corporation, or Government activity), which controls the design and characteristics of the item by means of its engineering drawings, specifications standards and inspection requirements to identify an item or range of items.

(3) STOCK NUMBER column. This column lists the NSN for the associated part number and manufacturer identified in the PART NUMBER and FSCM columns to the left.

(4) FIG. column. This column lists the number of the figure where the item is identified/located in Section II and III.

(5) ITEM column. The item number is that number assigned to the item as it appears in the figure referenced in the adjacent figure number column.

5. Special Information.

ASSOCIATED PUBLICATIONS. The publication(s) listed below pertain to the vehicle and its components.

Publication	Short Title
TM 9-2350-311-10	Howitzer, Medium, Self-Propelled, 155 MM, M109A2; M109A3; and M109A4
TM 9-2350-311-20-1	Howitzer, Medium, Self-Propelled, 155 MM, M109A2; M109A3; and M109A4
TM 9-2350-311-34-1	Howitzer, Medium, Self-Propelled, 155 MM, M109A2; M109A3; and M109A4

6. How to Locate Repair Parts.

a. When National Stock Number or Part is Not Known:

(1) First. Using the table of contents, determine the assembly group or subassembly group to which the item belongs. This is necessary since figures are prepared for assembly groups and subassembly groups, and listings are divided into the same groups.

(2) Second. Find the figure covering the assembly group or subassembly group to which the item belongs.

b. When National Stock Number or Part is Known:

(1) First. Using the Index of National Stock Numbers or Part Number Index, find the pertinent National Stock Number or Part Number. The NSN index is in National Item Identification Number (NIIN) sequence (see 4.1(1)). The part numbers in the Part Number index are listed in ascending alphanumeric sequence (see 4. b). Both indexes cross-reference you to the illustration figure and item number of the item you are looking for.

(2) Second. After finding the figure and item number, verify that the item is the one you're looking for, then locate the item number in the repair parts list for the figure.

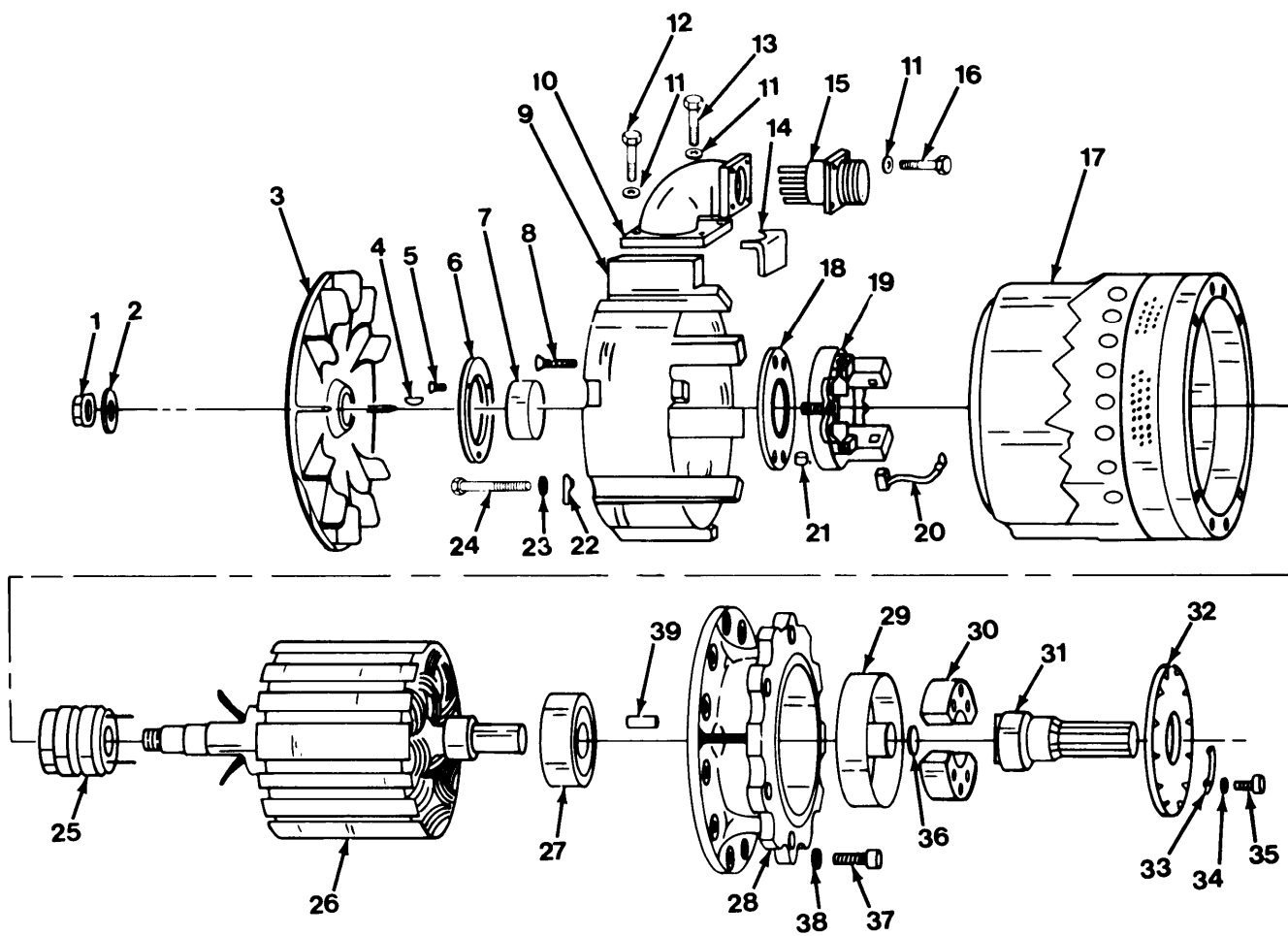

FIGURE 1. ALTERNATOR

(1) ITEM NO	(2) SMR CODE	(3) FSCM	(4) PART NUMBER	(5) DESCRIPTION AND USABLE ON CODE (UOC)	(6) QTY
GROUP 06 ELECTRICAL SYSTEM					
GROUP 0601 GENERATOR, ALTERNATOR.					
FIG. 01 GENERATOR, ALTERNATING CURRENT.					
1	PAFZZ	35510	36499	NUT 1/2-20 HEX LOCK	1
2	PAFZZ	35510	3249	WASHER, FLAT	1
3	PAFHH	35510	95934	IMPELLER, FAN, AXIAL	1
4	PAFZZ	96906	MS35756-5	KEY, WOODRUFF	1
5	PAFZZ	96906	MS35190-251	SCREW, MACHINE	3
6	PAFZZ	35510	21656	RETAINER, BEARING	1
7	PAFZZ	35510	28441	BEARING, BALL, ANNULA	1
8	PAFZZ	96906	MS3510-256	SCREW, MACHINE	4
9	XAFZZ	35510	59831	HOUSING, S.R. END	1
10	PAFZZ	19207	7716691	ELBOW, MASTER JUNCTI	1
11	PAFZZ	96906	MS35338-42	WASHER, LOCK	8
12	PAFZZ	96906	MS35265-45	SCREW, MACHINE	2
13	PAFZZ	35510	7984	SCREW, 8-32X7/8FL HD	2
14	PAFZZ	35510	59832	COVER, TERMINAL	1
15	PAFZZ	96906	MS3452W36-3P	CONNECTOR, RECEPTACL	1
16	PAFZZ	35510	13943	SCREW 8/32	4
17	XAFZZ	35510	A026 059870	ADAPTER, GENERATOR	1
18	PAFZZ	35510	30848	PLATE, RETAINING, SHA	1
19	PAFZZ	19207	8672841	HOLDER ASSEMBLY, ELE	1
20	PAFZZ	35510	35949	BRUSH, ELECTRICAL CO	4
21	PAFZZ	33510	2525	NUT, PLAIN, HEXAGON	2
22	PAFZZ	35510	6812	WASHER, KEY	2
23	PAFZZ	35510	2434	WASHER, LOCK	7
24	PAFZZ	35510	36817	SCREW, CAP, SOCKET HE	7
25	XAFZZ	35510	38724	RING, ELECTRICAL	1
26	XAFZZ	35510	36604	ROTOR, GENERATOR	1
27	PAFZZ	35510	36605	BEARING, BALL, ANNULA	1
28	XAFZZ	35510	36052	HOUSING, ALTERNATOR	1
29	PAFZZ	35510	95933	HOUSING, ELECTRICAL	1
30	PAFZZ	35510	71262	BLOCK, DRIVE	2
31	PAFZZ	35510	71261	SHAFT, SHOULDERED	1
32	PAFZZ	35510	36056	COVER, ALTERNATOR	1
33	PAFZZ	35510	36325	WASHER, LOCK	6
34	PAFZZ	35510	5584	WASHER, LOCK	16
35	PAFZZ	35510	36324	SCREW, MACHINE	12
36	PAFZZ	35510	30873	RING, RETAINING	1
37	PAFZZ	35510	54291	SCREW, 1/4-20X3/4SOC	12
38	PAFZZ	35510	2523	WASHER, LOCK	12
39	PAFZZ	96906	MS20066-120	KEY, MACHINE	1

END OF FIGURE

CROSS-REFERENCE INDEXES

NATIONAL STOCK NUMBER INDEX

STOCK NUMBER	FIG	ITEM	STOCK NUMBER	FIG	ITEM
5310-00-045-3299	1	11			
3110-00-109-1124	1	7			
3110-00-109-1157	1	27			
5310-00-143-5716	1	22			
5310-00-151-8801	1	33			
5365-00-263-3839	1	36			
5310-00-274-4546	1	2			
2920-00-441-9308	1	18			
5305-00-492-8807	1	35			
5305-00-543-2752	1	12			
5315-00-616-5515	1	4			
5977-00-695-6311	1	19			
5977-00-695-9212	1	20			
5305-00-722-3918	1	24			
2920-00-755-1212	1	6			
5975-00-771-6691	1	10			
5310-00-775-5139	1	23			
5310-00-775-5161	1	21			
5310-00-775-5182	1	38			
5305-00-958-5473	1	5			
5305-00-964-0780	1	8			
5315-00-990-2973	1	39			
2590-01-135-7469	1	32			
2920-01-165-0566	1	3			
2920-01-165-0575	1	29			
5935-01-261-8540	1	15			
3040-01-273-2488	1	31			

CROSS-REFERENCE INDEXES

PART NUMBER INDEX

FSCM	PART NUMBER	STOCK NUMBER	FIG	ITEM
35510	A026 059870		1	17
96906	MS20066-120	5315-00-990-2973	1	39
96906	MS3452W36-3P	5935-01-261-8540	1	15
96906	MS3510-256	5305-00-964-0780	1	8
96906	MS35190-251	5305-00-958-5473	1	5
96906	MS35265-45	5305-00-543-2752	1	12
96906	MS35338-42	5310-00-045-3299	1	11
96906	MS35756-5	5315-00-616-5515	1	4
35510	13943		1	16
35510	21656	2920-00-755-1212	1	6
35510	2434	5310-00-775-5139	1	23
35510	2523	5310-00-775-5182	1	38
35510	2525	5310-00-775-5161	1	21
35510	28441	3110-00-109-1124	1	7
35510	30848	2920-00-441-9308	1	18
35510	30873	5365-00-263-3839	1	36
35510	3249	5310-00-274-4546	1	2
35510	35949	5977-00-695-9212	1	20
35510	36052		1	28
35510	36056	2590-01-135-7469	1	32
35510	36324	5305-00-492-8807	1	35
35510	36325	5310-00-151-8801	1	33
35510	36499		1	1
35510	36604		1	26
35510	36605	3110-00-109-1157	1	27
35510	36817	5305-00-722-3918	1	24
35510	38724		1	25
35510	54291		1	37
35510	5584		1	34
35510	59831		1	9
35510	59832		1	14
35510	6812	5310-00-143-5716	1	22
35510	71261	3040-01-273-2488	1	31
35510	71262		1	30
19207	7716691	5975-00-771-6691	1	10
35510	7984		1	13
19207	8672841	5977-00-695-6311	1	19
35510	95933	2920-01-165-0575	1	29
35510	95934	2920-01-165-0566	1	3

SECTION IV
 CROSS-REFERENCE INDEXES

TM9-2920-258-30&P

FIGURE AND ITEM NUMBER INDEX

FIG	ITEM	STOCK NUMBER	FSCM	PART NUMBER
1	1		35510	36499
1	2	5310-00-274-4546	35510	3249
1	3	2920-01-165-0566	35510	95934
1	4	5315-00-616-5515	96906	MS35756-5
1	5	5305-00-958-5473	96906	MS35190-251
1	6	2920-00-755-1212	35510	21656
1	7	3110-00-109-1124	35510	28441
1	8	5305-00-964-0780	96906	MS3510-256
1	9		35510	59831
1	10	5975-00-771-6691	19207	7716691
1	11	5310-00-045-3299	96906	MS35338-42
1	12	5305-00-543-2752	96906	MS35265-45
1	13		35510	7984
1	14		35510	59832
1	15	5935-01-261-8540	96906	MS3452W36-3P
1	16		35510	13943
1	17		35510	A026 059870
1	18	2920-00-441-9308	35510	30848
1	19	5977-00-695-6311	19207	8672841
1	20	5977-00-695-9212	35510	35949
1	21	5310-00-775-5161	35510	2525
1	22	5310-00-143-5716	35510	6812
1	23	5310-00-775-5139	35510	2434
1	24	5305-00-722-3918	35510	36817
1	25		35510	38724
1	26		35510	36604
1	27	3110-00-109-1157	35510	36605
1	28		35510	36052
1	29	2920-01-165-0575	35510	95933
1	30		35510	71262
1	31	3040-01-273-2488	35510	71261
1	32	2590-01-135-7469	35510	36056
1	33	5310-00-151-8801	35510	36325
1	34		35510	5584
1	35	5305-00-492-8807	35510	36324
1	36	5365-00-263-3839	35510	30873
1	37		35510	54291
1	38	5310-00-775-5182	35510	2523
1	39	5315-00-990-2973	96906	MS20066-120

EXPENDABLE/DURABLE SUPPLIES AND MATERIALS LIST

ITEM NUMBER	LEVEL	NATIONAL STOCK NUMBER	DESCRIPTION FSCM & PART NUMBER	U/M
1	F	5350-00-221-0872	CLOTH, ABRASIVE, CROCUS (81348) P-C-458	SH.
2	F	6850-00-281-1985	DRY CLEANING SOLVENT (81348) P-D-680	GL.
3	F	7920-00-205-1711	RAG, WIPING, COTTON AND COTTON SYNTHETIC (81348)DDD-R-30, GRADE B	LB.
4	F	6850-00-177-5094	SILICONE COMPOUND (81349)	OZ.

APPENDIX D**ALTERNATOR TEST STAND PROCEDURES****SECTION I SUN ELECTRIC CORPORATION MODEL AGT-9 OR AGT-9A
TEST STAND****D-1 General**

The procedure in this section is performed to determine whether the Alternator is functioning in accordance with manufacturer's specifications for ampere and voltage output when operated under normal conditions. This procedure is for use with a Sun Electric Corporation Model AGT-9 or AGT-9A test stand. For further information, refer to TM 9-4910-485-12.

D-2 Testing Procedure Without Regulator

Refer to TM 9-4910-485-12 for test stand general preparation and operation procedures. Use the information contained below for testing procedures specific to the 180 ampere Alternator.

a Preparation

- 1 Connect the test cable to the Alternator.
- 2 Make sure that all controls on the test stand are positioned as shown on Table 2-1 of TM 9-4910-485-12.
- 3 Mount the direct drive Alternator to the low speed driving head.
- 4 Place the rectifier in the rectifier cooling chamber of the test stand.
- 5 Connect the cables and leads to the rectifier and binding posts of the side panel as shown in Figure D-1.
- 6 Before starting the varidrive, place the test stand switches and selectors in the following positions:
 - A Place the DC ammeter load and starter selector (1) in the 500A position.
 - B Set the DC ammeter field and battery charger selector (2) in the 15A position.
 - C Determine that the DC voltmeter range selector (5) is in the 50V position.
 - D Check to see that the DC voltmeter circuit selector (6) is in the RECT GEN position.
 - E Set the tachometer circuit selector in the DIRECT DRIVE position.
 - F Snap the field circuit switch (36) in the MANUAL position.
 - G All load switches (34) in the OFF position.
 - H Determine that the ground polarity switch (33) is in the negative (-) position.

FIGURE D-1 CONNECTING AND TESTING 24-VOLT 180 AMPERE ALTERNATOR WITHOUT REGULATOR

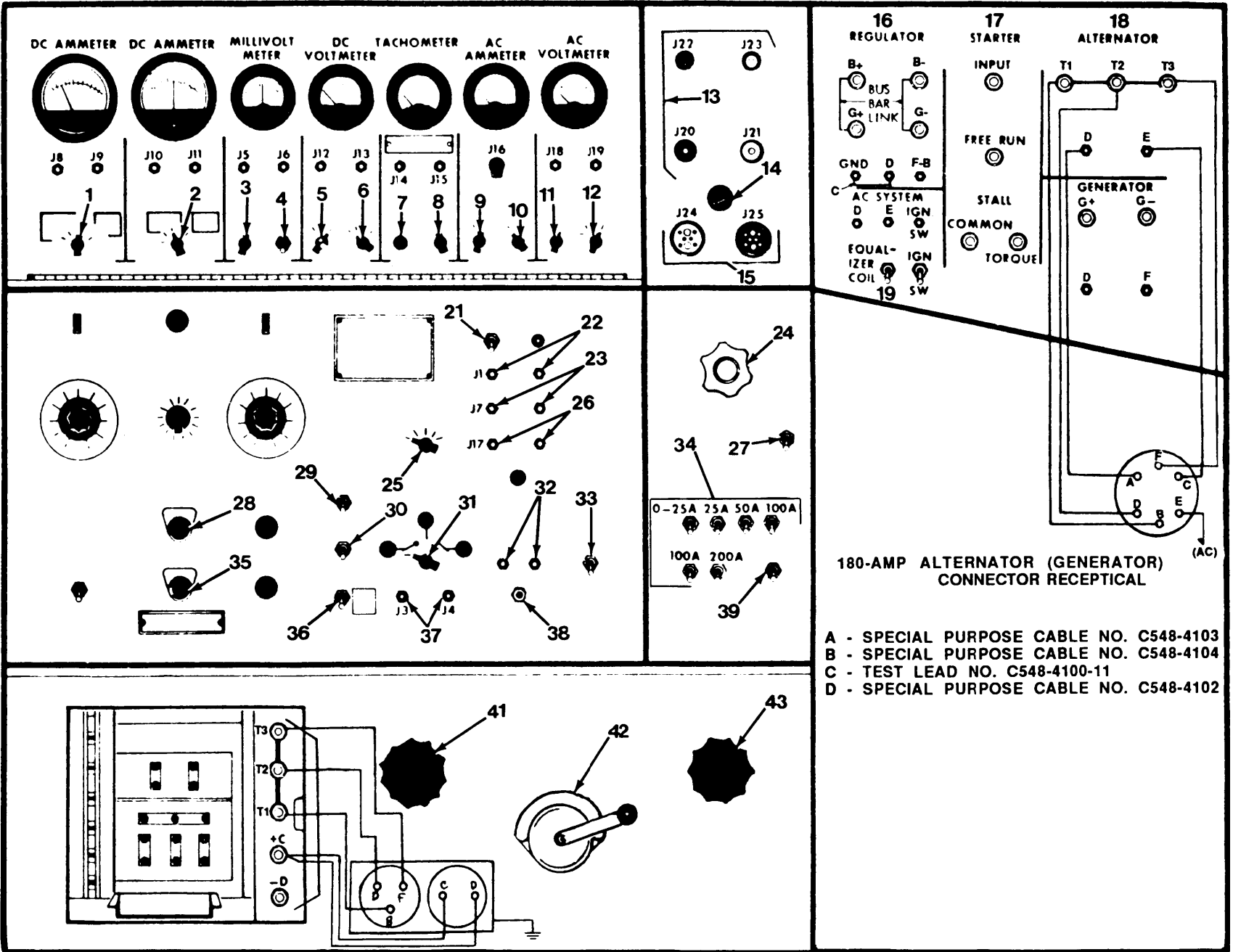

- I Place the AC ammeter range selector (9) in the 400A position.
- J Determine that the AC voltmeter range selector (11) is in the 50V position.
- K Make sure the field current control (41) is fully counterclockwise.
- L Ascertain that the battery selector (31) is in the OFF position.

b Testing

- 1 Start the varidrive by actuating the start button (28) and turn the drive speed control (42) counterclockwise until the Alternator is operating at 2800 rpm.
- 2 Place the battery selector (31) in the 24V position.
- 3 Turn the master load switch (39) to the ON position.

CAUTION

Never allow the voltage (DC vottmeter) to exceed 32 volts or the ampere reading on the DC ammeter (field and battery) to exceed 15 amperes or the rectifier maybe damaged.

- 4 Adjust the load current control (43) and the field current control (41) by turning clockwise simultaneously until the reading on the DC ammeter (load and starter) reads 180 amperes and the DC voltmeter reads 28 volts. The DC ammeter (field and battery charger) should read between 9 and 11 amperes.
- 5 Rotate the AC ammeter phase selector (10) through the A, B and C positions; the AC ammeter should read approximately the same in all positions.
- 6 Rotate the AC voltmeter circuit selector (12) through the T1 -T2, T1 -T3, and T2-T3 positions; the AC voltmeter should be approximately the same in all positions.
- 7 If the DC ammeter (field and battery charger) reads under 9 or over 12 amperes or other tests are not conclusive, the Alternator will require repair.
- 8 Using a multimeter, place the red lead on terminal "ac" and ground the black lead. Check for 12-16 volts AC.

c Test Stand Shutdown

- 1 Turn the field current (0-30 amps) counterclockwise.
- 2 Turn the battery select switch OFF.
- 3 Turn the master load switch OFF.
- 4 Turn the speed control clockwise and reduce speed to 1000 rpm.
- 5 Depress the STOP button.
- 6 Return all switches to the base setting.

D-3 Testing Procedure With Regulator

Refer to TM 9-4910-485-12 for test stand general preparation and operation procedures. Use the information contained below for testing procedures specific to the 180 amp Alternator.

a Preparation

- 1 Connect the test cable to the Alternator.
- 2 Make sure that all controls on the test stand are positioned as shown on Table 2-1 of TM 9-4910-485-12.
- 3 Mount the direct drive Alternator to the low speed driving head.
- 4 Place the rectifier in the rectifier cooling chamber of the test stand.
- 5 Connect the cables and leads to the rectifier, regulator and binding posts of the side panel as shown in Figure D-2.
- 6 Before starting the varidrive, place the test stand switches and selectors in the following positions:
 - A Place the DC ammeter load and starter selector (1) in the 500A position.
 - B Set the DC ammeter field and battery charger selector (2) in the 30A position.
 - C Determine that the DC voltmeter range selector (5) is in the 50V position.
 - D Check to see that the DC voltmeter circuit selector (6) is in the RECT GEN position.
 - E Snap the field circuit switch (36) in the REGULATOR position.
 - F All load switches (34) in the OFF position.
 - G Determine that the ground polarity switch (33) is in the negative (-) position.
 - H Place the AC ammeter range selector (9) in the 400A position.
 - I Determine that the AC voltmeter range selector (11) is in the 50V position.
 - J Make sure the field current control (41) is fully counterclockwise.
 - K Ascertain that the battery selector (31) is in the OFF position.

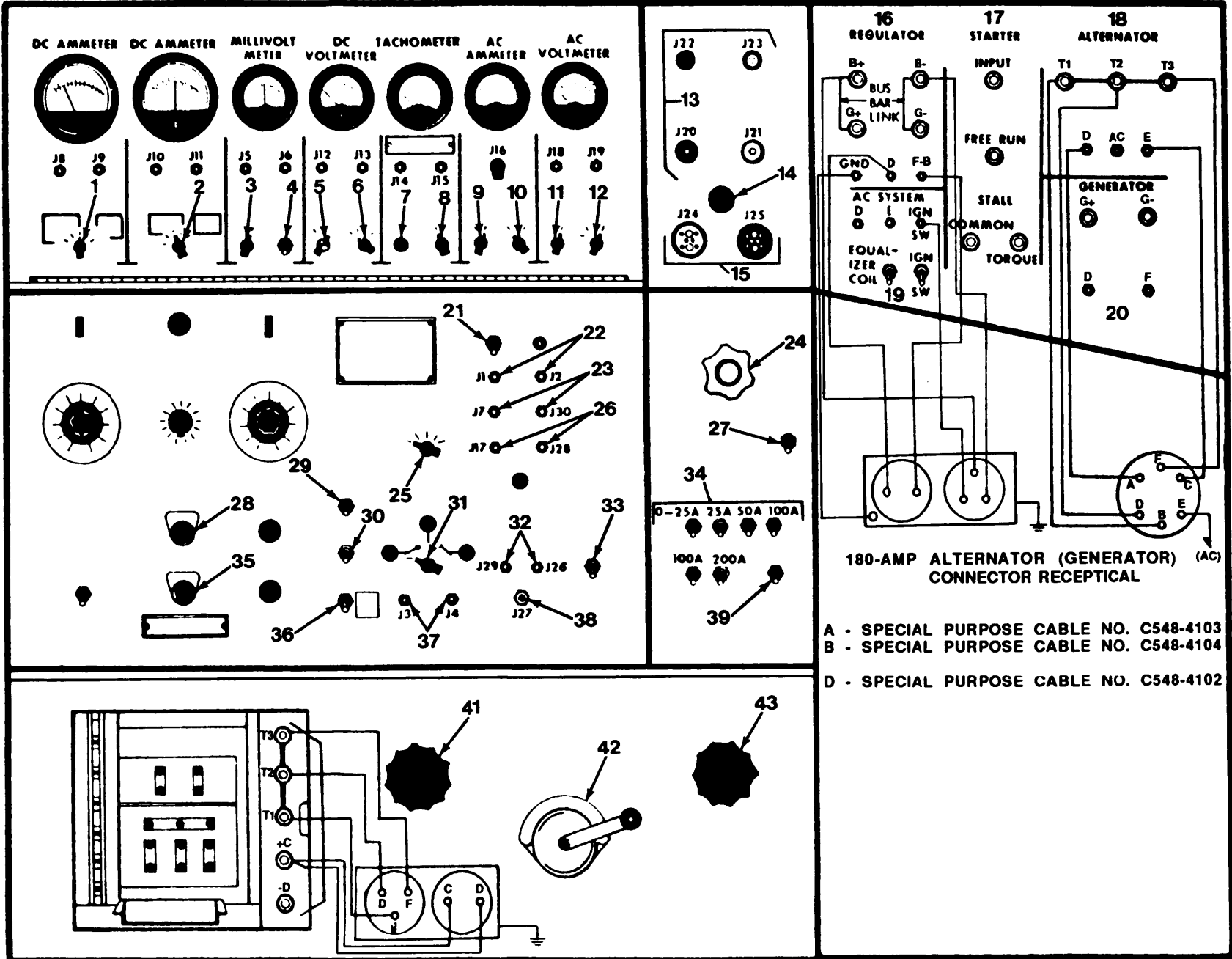

180-AMP ALTERNATOR (GENERATOR) (AC)
CONNECTOR RECEPTICAL

- A - SPECIAL PURPOSE CABLE NO. C548-4103
- B - SPECIAL PURPOSE CABLE NO. C548-4104
- D - SPECIAL PURPOSE CABLE NO. C548-4102

b Testing

- 1 Start the varidrive by actuating the start button (28) and turn the drive speed control (42) counterclockwise until the Alternator is operating at 2800 rpm.
- 2 Place the battery selector (31) in the 24V position.
- 3 Snap IGN (ignition) switch ON.
- 4 Turn the field current control (41) fully clockwise.
- 5 To obtain a 180A load snap the 100A, 50A, 25A, and 0-25A switches, of the load bank switches (34), and the master load switch (39) in the ON position.
- 6 Adjust the load current control (43) by turning clockwise until the reading on the DC ammeter (load and starter) reads 180 amperes.

CAUTION

Never allow the voltage (DC voltmeter) to exceed 32 volts or the ampere reading on the DC ammeter (field and battery) to exceed 15 amperes or the rectifier maybe damaged.

- 7 At this point the DC ammeter (load and starter) should read 180 amperes and the DC voltmeter should read 28 volts.
- 8 The DC ammeter (field and battery charger) should read between 9 and 11 amperes. If the voltage drops below 27.5 volts, the regulator requires adjustment.
- 9 Rotate the AC ammeter phase selector (10) through the A, B and C positions; the AC ammeter should read approximately the same in all positions.
- 10 Rotate the AC voltmeter circuit selector (12) through the T1 -T2, T1 -T3, and T2-T3 positions; the AC voltmeter should be approximately the same in all positions.
- 11 If the DC ammeter (field and battery charger) reads over 12 amperes or other tests are not conclusive, check the Alternator without the regulator in the circuit to determine which unit will require repair.
- 12 Using a multimeter, place the red lead on terminal "ac" and ground the black lead. Check for 12-16 volts AC.

c Test Stand Shutdown

- 1 Turn the ignition switch OFF.
- 2 Turn the master load switch OFF.
- 3 Turn the battery switch OFF.
- 4 Reduce test stand speed to 1000 rpm.
- 5 Depress the STOP button
- 6 Return all switches and controls to the base setting.

- 7 Remove the Alternator and regulator from the test stand.
- 8 Place all leads in the storage compartment of the test stand.

SECTION II UNITED 500-AMPERE MODEL GASR-500 TEST STAND

D-1 General

The procedure in this section is performed to determine whether the Alternator is functioning in accordance with manufacturer's specifications for ampere and voltage output when operated under normal conditions. This procedure is for use with a United 500-ampere Model GASR-500 test stand. For further information refer to TM 9-4910-663-12.

D-2 Testing Procedure Without Regulator

Refer to TM 9-4910-663-12 for test stand general preparation and operation procedures. Use the following information for testing procedures specific to the 180 ampere Alternator.

a Preparation

- 1 Connect the test cable to the Alternator.
- 2 Mount the Alternator on the test stand.
- 3 Set the controls and switches of the test stand to the base setting. The base setting is as follows:
 - A DC bad ammeter range switch at X 10.
 - B DC field ammeter range switch at X 6.
 - C Millivoltmeter range switch at X 10.
 - D DC voltmeter range switch at X 5.
 - E DC voltmeter select switch in the RECT/GEN position. (NOTE: Select switch position for test stand model 7458-4 set to EXT.)
 - F Tachometer select switch in the DIRECT DRIVE position.
 - G AC ammeter range switch at X 5.
 - H AC ammeter select switch in the T1 position.
 - I AC voltmeter range switch at X 2.
 - J AC voltmeter select switch in the T1-T2 position.
 - K External field exciter switch (AC system) in the OFF position.
 - L Generator field in the INT GND position.
 - M Polarity reversing switch in the NEG GND position.
 - N Field circuit in the OFF position.
 - O Fine control switch (0-5) in the OFF position.
 - P Field current increase (0-5) counterclockwise.

- Q Field circuit rheostat (0-30) counterclockwise.
- R Battery circuit selector in the OFF position.
- S Circuit breakers in the DOWN position (press to ensure the CB's are down).
- T Regulator check, fixed resistance method in the OFF position.
- U DC variable volts in the OFF position.
- V Load selection (all switches) in the OFF position.
- W Master load disconnect in the OFF position.
- X Variable load increase counterclockwise.
- Y Voltage adjusting increase (VAR) counterclockwise.
- Z Starter rheostat, approximately three turns counterclockwise from fully clockwise.
- AA Starlertest in the OFF position.
- AB Equalizer coil test in the OFF position.
- AC Ignition switch in the OFF position.
- AD Bus bars B+ and G+ In Place.
- AE Bus bars B- and G- In Place.
- AF DC variable power supply 0-32 VDC (front panel) counterclockwise.
- AG Charger time control in the OFF position.
- AH Battery charger variable load counterclockwise.
- AI D-sensing switch in the OFF position. (NOTE: New model United test stand has a D-sensing switch that is normally OFF [part number 7458-4].)

b Cable Connections

1 Wire the Alternator and rectifier to the test stand as follows (see Figure D-3):

A Connect the test cable from the Alternator to the test stand's alternator section.

B Connect the test lead from the test stand's GND (regulator section) to the test stand's connection point D (regulator section).

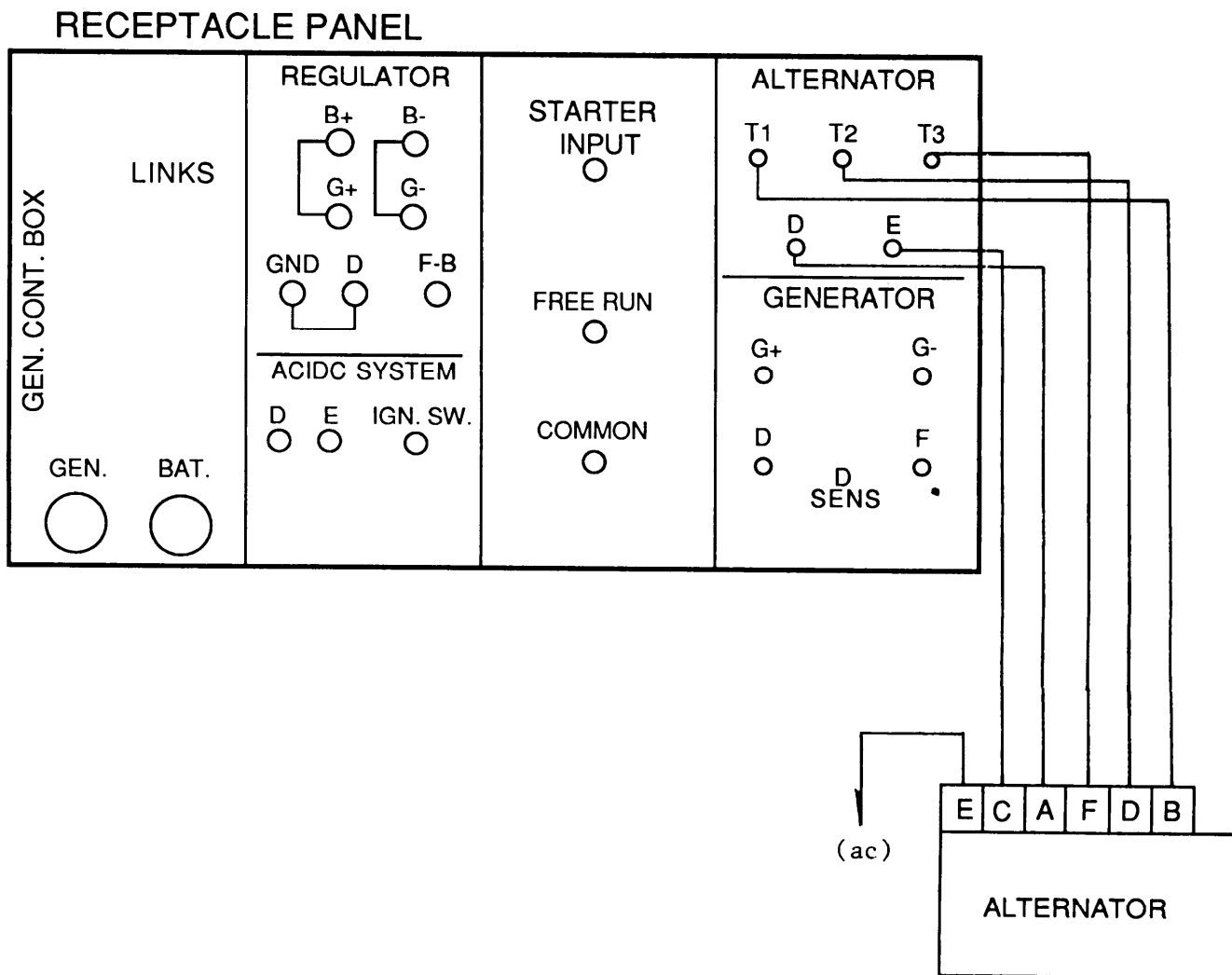

FIGURE D-3 180-AMP Alternator OUTPUT TEST WITHOUT REGULATOR

- C Connect the test cable from the rectifier's left connector receptacle to the test stand's connection points T1, T2 and T3 (rectifier section).
- D Connect the test cable from the rectifier's right connector receptacle to the test stand's connection point +C (both leads) (rectifier section).
- E Connect rectifier ground to D-.

c Switch and Control Positions

- 1 From the base setting, turn the:
 - A DC load ammeter switch to X 10.
 - B Field circuit switch to the MANUAL position.
 - C DC field ammeter switch to X 6.
 - D DC voltmeter output voltage select switch to REC/GEN.

NOTE

With the new model United test stand (part number 7458-4), be sure that the D-sensing switch is ON.

d Testing

- 1 Turn the master switch ON.
- 2 Depress the START button and hold for 3 to 5 seconds.
- 3 Turn the speed control counterclockwise until the tachometer reads 2800 rpm.
- 4 Turn the master load switch ON.
- 5 Turn the battery circuit select switch to 24 VOLTS.
- 6 The voltmeter will show battery voltage. Adjust voltage to 28 volts using field current rheostat (0-30 amps max).
- 7 Turn the 100-amp fixed, 50-amp fixed, 25-amp fixed and 0-to 25-amp variable load switches ON.
- 8 Turn the field current (0-30 amps max) control until the voltmeter reads 28 volts. The load ammeter should read approximately 180 amperes. The DC ammeter will read approximately 11 amperes.
- 9 Turn the variable load increase control until a drop of approximately 1 or 2 volts is indicated on the DC voltmeter. Then, increase the voltage back to 28 volts. The load amperage will increase as the voltage is increased. Do these steps until 180 amperes are indicated on the load ammeter.

NOTE

•The voltage has to be adjusted to 28 volts when any part of a load is added. Check the AC ammeter. While watching the AC ammeter, rotate the phase select switch through A, B and C positions. There should be no more than a 1-ampere difference between each phase.

•Check the AC voltmeter. While watching the AC voltmeter, rotate the select switch through the T1, T2; T1, T3; and T2, T3 positions. There should be no more than 1-volt difference between each circuit.

10 Using a multimeter, place the red lead on terminal "ac" and ground the black lead. Check for 12-16 volts AC.

11 If the Alternator meets the above requirements, it is serviceable.

e Test Stand Shutdown

- 1 Turn the field current (0-30 amps) counterclockwise.
- 2 Turn the battery select switch to the OFF position.
- 3 Turn the master load switch to the OFF position.
- 4 Turn the speed control clockwise and reduce speed to 1000 rpm.
- 5 Depress the STOP button.
- 6 Return all switches to the base setting.

D-3 Testing Procedure With Regulator

Refer to TM 9-4910-663-12 for test stand general preparation and operation procedures. Use the following information for testing procedures specific to the 180 ampere Alternator (ref Figure D-4).

a Preparation

- 1 Connect the test cable to the Alternator.
- 2 Mount the Alternator on the test stand.
- 3 Set the controls and switches of the test stand to the base setting. The base setting is as follows:
 - A DC bad ammeter range switch at X 10.
 - B DC field ammeter range switch at X 6.
 - C Millivoltmeter range switch at X 10.
 - D DC voltmeter range switch at X 5.
 - E DC voltmeter select switch in the RECT/GEN position. (NOTE: Select switch position for test stand model 7458-4 set to EXT.)
 - F AC ammeter range switch at X 5.
 - G AC ammeter select switch in the T1 position.
 - H AC voltmeter range switch at X 2.
 - I AC voltmeter select switch in the T1-T2 position.
 - J External field exciter switch (AC system) in the OFF position.
 - K Generator field in the INT GND position.
 - L Polarity reversing switch in the NEG GND position.

- M Field circuit in the OFF position.
- N Fine control switch (0-5) in the OFF position.
- O Field current increase (0-5) counterclockwise.
- P Field circuit rheostat (0-30) counterclockwise.
- Q Battery circuit selector in the OFF position.
- R Circuit breakers in the DOWN position (press to ensure the CB's are down).
- S Regulator check, fixed resistance method in the OFF position.
- T DC variable volts in the OFF position.
- U Load selection (all switches) in the OFF position.
- V Master load disconnect in the OFF position.
- W Variable load increase counterclockwise.
- X Voltage adjusting increase (VAR) counterclockwise.
- Y Starter rheostat, approximately three turns counterclockwise from fully clockwise.
- Z Starter test in the OFF position.
- AA Equalizer coil test in the OFF position.
- AB Ignition switch in the OFF position.
- AC Bus bars B+ and G+ In Place.
- AD Bus bars B- and G- In Place.
- AE DC variable power supply 0-32 VDC (front panel) counterclockwise.
- AF Charger time control in the OFF position.
- AG Battery charger variable load counterclockwise.
- AH D-sensing switch in the OFF position. (NOTE: New model United test stand has a D-sensing switch that is normally OFF [part number 7458-4].)

b Cable Connections

- 1 Wire the Alternator and rectifier to the test stand as follows (see Figure D-4):

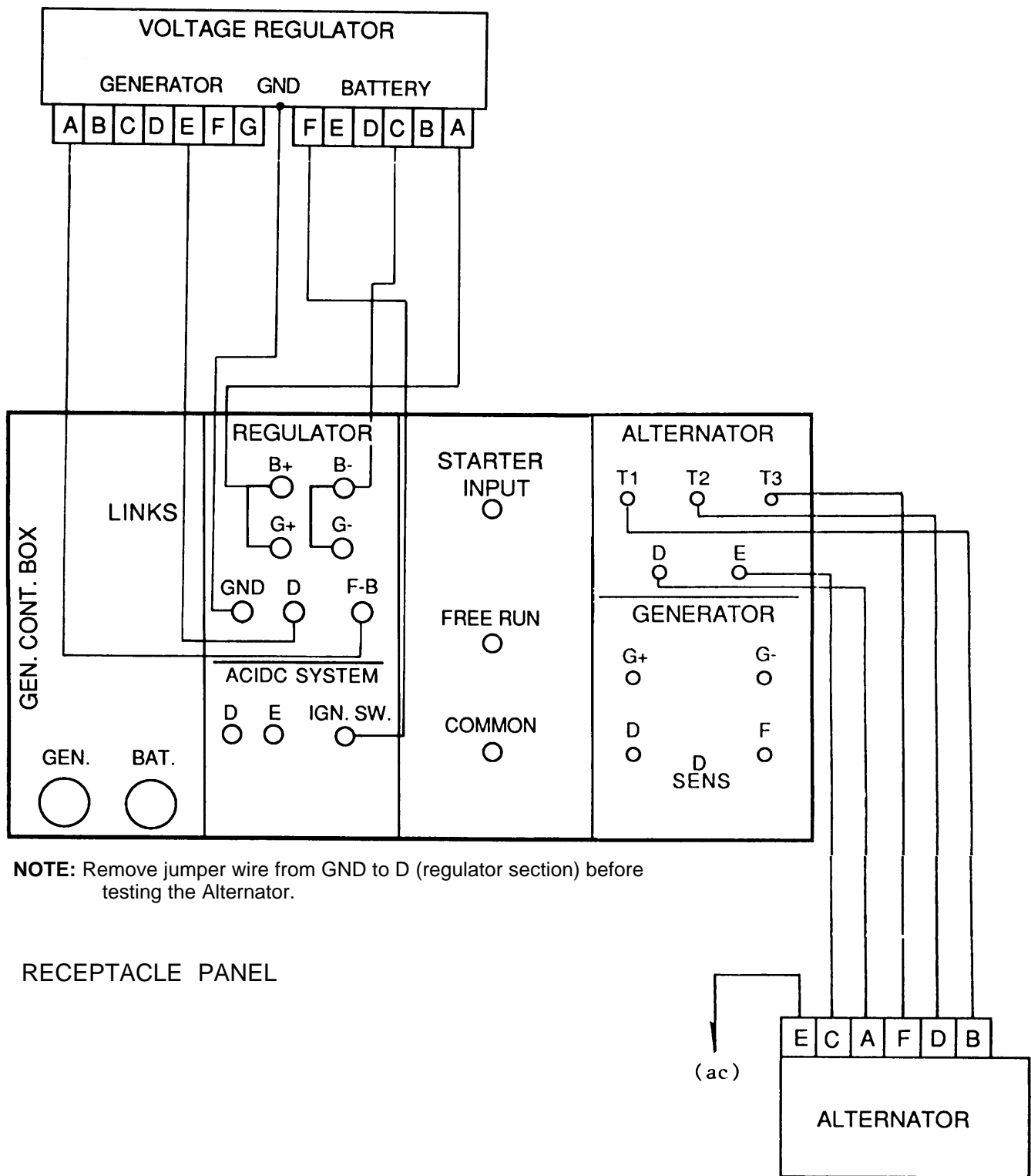

FIGURE D-4. 180-ALTERNATOR OUTPUT TEST WITH REGULATOR

- A Connect the test cable from the Alternator to the test stand's alternator section.
- B Connect the test cable from the rectifier's left connector receptacle to the test stand's connection points T1, T2 and T3 (rectifier section).
- C Connect the test cable from the rectifier's right connector receptacle to the test stand's connection point +C (both leads) (rectifier section).
- D Connect rectifier ground to D-.

NOTE

Before the Alternator can be tested, a regulator must be connected. The regulator does not require special mounting; simply set it on any flat surface, such as a workbench beside the test stand.

- E Connect the regulator to the test stand as shown in Figure D-4.

c Switch and Control Positions

- 1 From the base setting, turn the:
 - A DC load ammeter switch to X 10.
 - B Field circuit switch to the REGULATOR position.
 - C DC field ammeter switch to X 6.
 - D DC voltmeter output voltage select switch to REC/GEN (on model 7458-4 only).

NOTE

With the new model United test stand (part number 7458-4), be sure that the D-sensing switch is ON.

d Testing

- 1 Turn the master switch ON.
- 2 Depress the START button and hold for 3 to 5 seconds.
- 3 Turn the speed control counterclockwise until the tachometer reads 2800 rpm.
- 4 Turn the master load switch ON.
- 5 Turn the battery circuit select switch to 24 VOLTS.
- 6 Turn the ignition switch ON.
- 7 The voltmeter will show output voltage. Adjust voltage to 28 volts.
- 8 Turn the 100-amp fixed, 50-amp fixed, 25-amp fixed and 0- to 25-amp variable load switches ON.
- 9 Turn the variable load increase control until a drop of approximately 1 or 2 volts is indicated on the DC voltmeter. Then, increase the voltage back to 28 volts. The load amperage will increase as the voltage is increased. Do these steps until 180 amperes are indicated on the load ammeter.

NOTE

Ž The voltage has to be adjusted to 28 volts when any part of a load is added. Check the AC ammeter. While watching the AC ammeter, rotate the phase select switch through A, B and C positions. There should be no more than a 1-ampere difference between each phase.

• Check the AC voltmeter. While watching the AC voltmeter, rotate the select switch through the T1, T2; T1, T3; and T2, T3 positions. There should be no more than 1-volt difference between each circuit.

10 Using a multimeter, place the red lead on terminal "ac" and ground the black lead. Check for 12-16 volts AC.

11 If the Alternator meets the above requirements, it is serviceable.

e Test Stand Shutdown

CAUTION

Do not turn master load switch OFF first as damage to equipment may result.

- 1 Turn the ignition switch OFF.
- 2 Turn the master load switch OFF.
- 3 Turn the battery switch OFF.
- 4 Reduce test stand speed to 1000 rpm.
- 5 Depress the STOP button.
- 6 Return all switches and controls to the base setting.
- 7 Remove the Alternator and regulator from the test stand.
- 8 Place all leads in the storage compartment of the test stand.

INDEX

A	M
Alternator:	Maintenance Forms 1-1
Assembly 3-16	Major Components 1-2
Alternator Cleaning Instructions 3-3	Multimeter Tests 2-3
Alternator Disassembly 3-4	
Alternator Inspection 3-9	P
Alternator Principles of Operation 3-1	Parts, Replacement of 3-2
Alternator Repair 3-4	Preparation for Storage or Shipment 1-1
Alternator Test Stand Procedures D-1	Principles of Operation 3-1
Assembly of Alternator 3-16	
Army Materiel, Destruction of to Prevent	R
Enemy Use 1-1	
B	Raised Metal, Removing 3-2
Bearings, Ball and Roller 3-2	Records 1-1
Burrs, Removing 3-2	References A-1
	Removing Burrs, Scratches and Raised
C	Metal 3-2
Cleaning Instructions 3-3	Repair, Alternator 3-4
Common Tools 2-1	Repair Parts 2-1
	Repair Parts and Special Tools List B-1
D	Repairing Damaged Threads 3-3
Damaged Threads, Repairing 3-3	Replacement of Parts 3-2
Destruction of Army Materiel to Prevent	Reporting Equipment Improvement
Enemy Use 1-1	Recommendations (EIRs) 1-1
Disassembly of Alternator 3-4	Reports 1-1
	RPSTL B-1
E	S
Equipment Characteristics and Features 1-1	Safety Care and Handling 1-2
Equipment Data 1-2	Scope 1-1
Equipment Improvement Recommendations	Scratches, Removing 3-2
(EIRs), Reporting 1-1	Storage or Shipment, Preparation for 1-1
Expendable/Durable Supplies and	Sun Electric Corporation Test Stand D-1
Materials List C-1	
G	T
General Information 1-1	Test Stand Procedures D-1
General Instructions 3-1	Tools:
	Common 2-1
I	Special 2-1
Information, General 1-1	Troubleshooting 2-1
Inspection of Alternator 3-9	
Instructions:	U
Cleaning 3-3	United Test Stand D-8
General 3-1	
	W
	Wear Limits 3-13

By Order of the Secretary of the Army:

CARL E. VUONO
General, United States Army
Chief of Staff

Official:

WILLIAM J. MEEHAN II
Brigadier General, United States Army
The Adjutant General

Distribution:

To be distributed in accordance with DA Form 12-37, Direct Support and General Support maintenance requirements for Howitzer, Med, S-P, 155MM, M109A.2.

*U.S . GOVERNMENT PRINTING OFFICE: 1989 643-025/00008

RECOMMENDED CHANGES TO EQUIPMENT TECHNICAL PUBLICATIONS



THEN... JOT DOWN THE DOPE ABOUT IT ON THIS FORM. CAREFULLY TEAR IT OUT. FOLD IT AND DROP IT IN THE MAIL!

SOMETHING WRONG WITH THIS PUBLICATION?

FROM: (PRINT YOUR UNIT'S COMPLETE ADDRESS)

YOUR ADDRESS

DATE SENT

DATE YOU MAILED THIS FORM

PUBLICATION NUMBER

TM 9-2920-258-30&P

PUBLICATION DATE

18 APRIL 1989

PUBLICATION TITLE

ALTERNATER, 180 AMPERES, MODEL 5520AB

BE EXACT PIN-POINT WHERE IT IS

PAGE NO	PARA-GRAPH	FIGURE NO	TABLE NO
3-8	3-8		

IN THIS SPACE TELL WHAT IS WRONG AND WHAT SHOULD BE DONE ABOUT IT:

Callout 44 should point to leads.

SAMPLE

PRINTED NAME GRADE OR TITLE AND TELEPHONE NUMBER

SIGN HERE

FILL IN YOUR
UNIT'S ADDRESS



DEPARTMENT OF THE ARMY

SAMPLE

SOLO BACK

POSTAGE AND FEES PAID
DEPARTMENT OF THE ARMY
DOD 314



OFFICIAL BUSINESS
PENALTY FOR PRIVATE USE \$300

TEAR ALONG PERFORATED LINE

Commander
US Army Tank-Automotive Command
ATTN: AMSTA-MB
Warren, Michigan 48397-5000

RECOMMENDED CHANGES TO EQUIPMENT TECHNICAL PUBLICATIONS



SOMETHING WRONG WITH THIS PUBLICATION?

THEN... JOT DOWN THE DOPE ABOUT IT ON THIS FORM. CAREFULLY TEAR IT OUT. FOLD IT AND DROP IT IN THE MAIL!

FROM: (PRINT YOUR UNIT'S COMPLETE ADDRESS)

DATE SENT

PUBLICATION NUMBER
TM 9-2920-258-30&P

PUBLICATION DATE
25 APRIL 1989

PUBLICATION TITLE
ALTERNATER, 180 AMPERES, MODEL 5520AB

BE EXACT... PIN-POINT WHERE IT IS

PAGE NO	PARA-GRAPH	FIGURE NO	TABLE NO

IN THIS SPACE TELL WHAT IS WRONG AND WHAT SHOULD BE DONE ABOUT IT:

Large empty space for providing details of the error and recommended corrections.

PRINTED NAME, GRADE OR TITLE, AND TELEPHONE NUMBER

SIGN HERE

FILL IN YOUR
UNIT'S ADDRESS

FOLD BACK

DEPARTMENT OF THE ARMY

POSTAGE AND FEES PAID
DEPARTMENT OF THE ARMY
DOD 314



OFFICIAL BUSINESS
PENALTY FOR PRIVATE USE \$300

TEAR ALONG PERFORATED LINE

Commander
US Army Tank-Automotive Command
ATTN: AMSTA-MB
Warren, Michigan 48397-5000

FILL IN YOUR
UNIT'S ADDRESS

FOLD BACK

DEPARTMENT OF THE ARMY

POSTAGE AND FEES PAID
DEPARTMENT OF THE ARMY
DOD 314



OFFICIAL BUSINESS
PENALTY FOR PRIVATE USE \$300

Commander
US Army Tank-Automotive Command
ATTN: AMSTA-MB
Warren, Michigan 48397-5000

TEAR ALONG PERFORATED LINE

RECOMMENDED CHANGES TO EQUIPMENT TECHNICAL PUBLICATIONS

SOMETHING WRONG WITH THIS PUBLICATION?



THEN... JOT DOWN THE DOPE ABOUT IT ON THIS FORM. CAREFULLY TEAR IT OUT. FOLD IT AND DROP IT IN THE MAIL!

FROM: (PRINT YOUR UNIT'S COMPLETE ADDRESS)

DATE SENT

PUBLICATION NUMBER

TM 9-2920-258-30&P

PUBLICATION DATE

25 APRIL 1989

PUBLICATION TITLE

ALTERNATER, 180 AMPERES, MODEL 5520AB

BE EXACT. PIN-POINT WHERE IT IS

PAGE
NO

PARA-
GRAPH

FIGURE
NO

TABLE
NO

IN THIS SPACE TELL WHAT IS WRONG AND WHAT SHOULD BE DONE ABOUT IT:

PRINTED NAME, GRADE OR TITLE, AND TELEPHONE NUMBER

SIGN HERE

DA FORM 1 JUL 79 **2028-2**

PREVIOUS EDITIONS ARE OBSOLETE.

PS --IF YOUR OUTFIT WANTS TO KNOW ABOUT YOUR RECOMMENDATION MAKE A CARBON COPY OF THIS AND GIVE IT TO YOUR HEADQUARTERS

FILL IN YOUR
UNIT'S ADDRESS

FOLD BACK

TEAR ALONG PERFORATED LINE

DEPARTMENT OF THE ARMY

OFFICIAL BUSINESS
PENALTY FOR PRIVATE USE \$300

POSTAGE AND FEES PAID
DEPARTMENT OF THE ARMY
DOD 314



Commander
US Army Tank-Automotive Command
ATTN:AMSTA-MB
Warren, Michigan 48397-5000

THE METRIC SYSTEM AND EQUIVALENTS

LINEAR MEASURE

1 Centimeter = 10 Millimeters = 0.01 Meters = 0.3937 Inches
 1 Meter = 100 Centimeters = 1000 Millimeters = 39.37 Inches
 1 Kilometer = 1000 Meters = 0.621 Miles

WEIGHTS

1 Gram = 0.001 Kilograms = 1000 Milligrams = 0.035 Ounces
 1 Kilogram = 1000 Grams = 2.2 Lb.
 1 Metric Ton = 1000 Kilograms = 1 Megagram = 1.1 Short Tons

LIQUID MEASURE

1 Milliliter = 0.001 Liters = 0.0338 Fluid Ounces
 1 Liter = 1000 Milliliters = 33.82 Fluid Ounces

SQUARE MEASURE

1 Sq. Centimeter = 100 Sq. Millimeters = 0.155 Sq. Inches
 1 Sq. Meter = 10,000 Sq. Centimeters = 10.76 Sq. Feet
 1 Sq. Kilometer = 1,000,000 Sq. Meters = 0.386 Sq. Miles

CUBIC MEASURE

1 Cu. Centimeter = 1000 Cu. Millimeters = 0.06 Cu. Inches
 1 Cu. Meter = 1,000,000 Cu. Centimeters = 35.31 Cu. Feet

TEMPERATURE

$5/9(^{\circ}\text{F} - 32) = ^{\circ}\text{C}$
 212° Fahrenheit is equivalent to 100° Celsius
 90° Fahrenheit is equivalent to 32.2° Celsius
 32° Fahrenheit is equivalent to 0° Celsius
 $9/5^{\circ}\text{C} + 32 = ^{\circ}\text{F}$

APPROXIMATE CONVERSION FACTORS

TO CHANGE	TO	MULTIPLY BY
Inches	Centimeters	2.540
Feet	Meters	0.305
Yards	Meters	0.914
Miles	Kilometers	1.609
Square Inches	Square Centimeters	6.451
Square Feet	Square Meters	0.093
Square Yards	Square Meters	0.836
Square Miles	Square Kilometers	2.590
Acres	Square Hectometers	0.405
Cubic Feet	Cubic Meters	0.028
Cubic Yards	Cubic Meters	0.765
Fluid Ounces	Milliliters	29.573
Pints	Liters	0.473
Quarts	Liters	0.946
Gallons	Liters	3.785
Ounces	Grams	28.349
Pounds	Kilograms	0.454
Short Tons	Metric Tons	0.907
Pound-Feet	Newton-Meters	1.356
Pounds per Square Inch	Kilopascals	6.895
Miles per Gallon	Kilometers per Liter	0.425
Miles per Hour	Kilometers per Hour	1.609

TO CHANGE	TO	MULTIPLY BY
Centimeters	Inches	0.394
Meters	Feet	3.280
Meters	Yards	1.094
Kilometers	Miles	0.621
Square Centimeters	Square Inches	0.155
Square Meters	Square Feet	10.764
Square Meters	Square Yards	1.196
Square Kilometers	Square Miles	0.386
Square Hectometers	Acres	2.471
Cubic Meters	Cubic Feet	35.315
Cubic Meters	Cubic Yards	1.308
Milliliters	Fluid Ounces	0.034
Liters	Pints	2.113
Liters	Quarts	1.057
Liters	Gallons	0.264
Grams	Ounces	0.035
Kilograms	Pounds	2.205
Metric Tons	Short Tons	1.102
Newton-Meters	Pound-Feet	0.738
Kilopascals	Pounds per Square Inch	0.145
Kilometers per Liter	Miles per Gallon	2.354
Kilometers per Hour	Miles per Hour	0.621

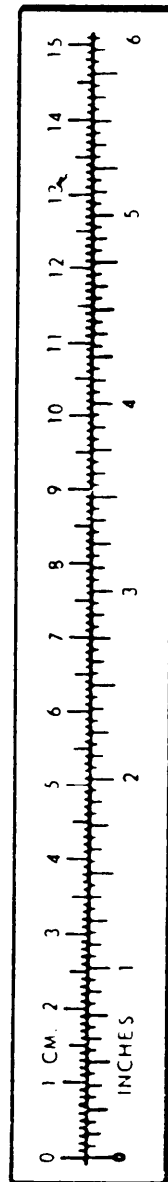

PIN: 065796-000